

Design Guide COMX Communication Modules

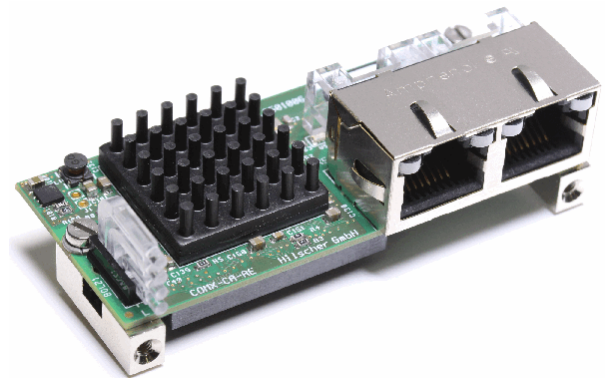

Hilscher Gesellschaft für Systemautomation mbH

www.hilscher.com

DOC100901DG26EN | Revision 26 | English | 2022-03 | Released | Public

Table of contents

1	Introduction	4
1.1	About this document.....	4
1.2	Comparison COMX and COM modules	5
1.3	List of revisions	6
1.4	Technical features.....	7
1.5	Module names.....	9
1.6	References to documents	10
2	Design-in - Mechanical aspects	11
2.1	Type of COMX modules.....	11
2.2	Mechanical dimensions.....	13
2.2.1	Common mechanical dimensions for COMX modules.....	13
2.2.2	Mechanical dimensions of COMX modules.....	13
2.3	Type of connector.....	22
2.3.1	Storage and contact reliability of host-side connector.....	24
2.4	Mounting of COMX modules	25
2.5	Material recommendation for the faceplate	31
2.6	Designation of the COMX module.....	31
2.7	Meaning of the address switch.....	31
2.7.1	PROFIBUS DP Slave.....	31
2.7.2	CANopen Slave	32
2.7.3	DeviceNet Slave	32
2.7.4	CC-Link Slave.....	33
2.7.5	EtherCAT Slave	34
3	Design-in - Electrical aspects.....	35
3.1	Host interface	35
3.1.1	Host interface overview: Dual-port memory sizes and modes.....	35
3.1.2	Host interface: Parallel or serial dual-port memory mode	36
3.1.2.1	COMX 100.....	36
3.1.2.2	COMX 51 and COMX 52.....	36
3.1.3	COMX pin assignment of the system bus connector X1 – Parallel mode.....	37
3.1.4	COMX pin assignment of the system bus connector X1 – Serial mode.....	39
3.1.5	PAD type explanation.....	41
3.1.6	Signal overview and pin assignment of the fieldbus connector X2 on COMX CN.....	43
3.1.6.1	Fieldbus connector X2 for CC-Link Slave	43
3.1.6.2	Fieldbus connector X2 for CANopen-Master/-Slave	44
3.1.6.3	Fieldbus Connector X2 for DeviceNet-Master/-Slave	45
3.1.6.4	Fieldbus Connector X2 for PROFIBUS-Master/-Slave.....	46
3.1.6.5	Fieldbus Connector X2 for Real Time Ethernet.....	47
3.1.7	Common signals of the host interface.....	49
3.1.7.1	Power supply of the COMX modules	49
3.1.7.2	RESET signal	49
3.1.8	Signals of the host interface – Parallel dual-port memory mode	49
3.1.8.1	The dual-port memory bus of COMX	49
3.1.8.2	Address bus and data bus.....	50
3.1.8.3	Dual-port memory control lines.....	50
3.1.8.4	Interrupt line to the host system.....	50
3.1.8.5	BUSY line to the host system	51
3.1.8.6	Interfacing to the dual-port memory for COMX.....	51
3.1.8.7	Timing diagram parallel dual-port memory interface.....	52
3.1.8.8	Integration of COMX module into a host system	54
3.1.9	Signals of the host interface – Serial dual-port memory mode	55
3.2	Fieldbus interface.....	56
3.3	LEDs	57
3.4	Diagnostic interface.....	59
3.4.1	Diagnostic interface RS232C.....	59
3.4.2	Diagnostic interface USB.....	60
3.5	SYNC signals	63
4	Technical data	64
4.1	Product tests	66
4.1.1	COMX 51CA-RE	66
4.1.2	COMX 51CA-RE\R.....	66

4.1.3	COMX 51CN-RE	66
4.1.4	COMX 52CA-CCS	67
4.1.5	COMX 52CA-COS	67
4.1.6	COMX 52CA-DPS	67
4.1.7	COMX 52CA-DNS	67
4.1.8	COMX 52CN-CCS	68
4.1.9	COMX 52CN-COS	68
4.1.10	COMX 52CN-DPS	68
4.1.11	COMX 52CN-DNS	69
4.1.12	COMX 100CA-CO	69
4.1.13	COMX 100CA-DN	69
4.1.14	COMX 100CA-DP	70
4.1.15	COMX 100CA-RE	70
4.1.16	COMX 100CN-CO	70
4.1.17	COMX 100CN-DN	71
4.1.18	COMX 100CN-DP	71
4.1.19	COMX 100CN-RE	71
5	Appendix	72
5.1	Legal notes	72
5.2	Registered trademarks	75
5.3	List of tables	76
5.4	List of figures	77
5.5	Contacts	78

1 Introduction

1.1 About this document

COMX means **C**ommunication **M**odules **netX**. These modules provide a universal and easy to use fieldbus interface for integration on various host systems. Through the set of standard application interfaces and the same board dimensions in each COMX family it is easy to switch between the different Ethernet and fieldbus systems.

This manual describes only the hardware part of the modules.

The COMX communication modules is a generation of modules and offer beside fieldbus communication also Real-Time Ethernet communication. The application interface is different (not compatible) compared to COM modules. The application interface of the COMX modules is common to all our COMX communication modules, and PC cards CIFX and netJACK communication modules described in our toolkit manual, dual-port memory interface manual and the Real Time Ethernet respectively fieldbus-related details are defined in our Protocol API Manuals.

COM modules are the previous generation of communication modules. The COM modules are described in a separate manual. The following two tables give a comparison of both COM and COMX modules.

1.2 Comparison COMX and COM modules

Basic differences between COM and COMX

	COM	COMX
Processor	EC1	netX
Host Interface	8 Bit	8 / 16 Bit
Dual-Port Memory size	2 KByte or 8 KByte	8 KByte or 16 KByte See section <i>Host interface overview: Dual-port memory sizes and modes</i> on page 35.
USB Interface	No	Yes
Serial dual-port memory	No	Yes. See section <i>Host interface overview: Dual-port memory sizes and modes</i> on page 35.

Table 1: Basic differences between COM and COMX

Comparison of supported protocols for COM and COMX

Protocol	COM	COMX (in this manual)
AS-Interface Master	supported	-
CANopen Master	supported	supported
CANopen Slave	supported	supported
CC-Link Slave	supported	supported
CC-Link IE Field Basic Slave	-	supported
DeviceNet Master	supported	supported
DeviceNet Slave	supported	supported
InterBus Slave	supported	not supported by netX technology
PROFIBUS DP Master	supported	supported
PROFIBUS DP Slave	supported	supported
PROFIBUS MPI	supported	supported
EtherCAT Master	-	supported
EtherCAT Slave	-	supported
EtherNet/IP Scanner (Master)	-	supported
EtherNet/IP Adapter (Slave)	supported	supported
Open Modbus/TCP	supported	supported
POWERLINK Controlled Node	-	supported
PROFINET IO Controller	-	supported
PROFINET IO Device	-	supported
Sercos Master (third generation)	-	supported
Sercos Slave (third generation)	-	supported
Sercos II (second generation)	supported	not supported by netX technology
VARAN Client (Slave)	-	supported

Table 2: Comparison of supported protocols for COM and COMX

1.3 List of revisions

Rev	Date	Name	Chapter	Revision
20	2015-09-11	HH	All 2.2.2 3.1.9 4.1.1	COMX 51CN-RE added. Section <i>Mechanical dimensions of COMX modules</i> : updated to M0300637, updated to M0600176 Section Signals of the host interface – Serial dual-port memory mode: Figure 24 updated. Section COMX 51CA-RE, COMX 51CN-RE added.
21	2015-11-30	HH RG RG HH	2.2.2 3.1.2.1, 3.1.2.2 3.5 4	Section <i>Mechanical dimensions of COMX modules</i> : updated to M0203764, updated to M0204664. Note added about power-cycle required in order to switch 8/16 bit mode. Section <i>SYNC signals</i> extended due to PROFINET IO IRT certification. Max. Current for COMX 51XX-RE reduced to 580 mA.
22	2018-12-07	HH	All All 2.2.2	CC-Link IE Field Basic Slave added. CC-Link IE Field Slave prepared. Section <i>Mechanical dimensions of COMX modules</i> : updated to M1100132.
23	2020-11-27	RGÖ, HHE	All	COMX 52CA-DPS, -DNS, -COS, -CCS added. COMX 10XX-XXX removed. COMX 50CA-REFO, COMX 50CA-CCS removed.
24	2021-02-19	RGÖ, HHE	All	COMX 52CN-DPS, -DNS, -COS added.
25	2021-08-10	RGÖ, HHE	All	COMX 51CA-RE\R EtherCAT module with rotary switches added.
26	2022-03-30	RGÖ	All	COMX 52CN-CCS added.

Table 3: List of revisions

1.4 Technical features

Common technical features for COMX

- All leading Fieldbus and Real-Time Ethernet Protocols available as Master and Slave
- One common hardware for all Real Time Ethernet Protocols
- Easy to use dual-port memory interface, with additional serial and diagnostic interface
- USB or serial diagnostic interface at COMX
- Host interface is designed for 8 KByte (COMX 52) and for 16 KByte (COMX 51 and COMX 100) address space of the dual-port memory with selectable bus width of 8 or 16 bit.
- 3.3 V power supply reduces power consumption
- Small footprint for the host connector with 50 mil grid
- Solid mechanical assembly and a massive connection to earth ground by metal blocks special design for the requirements of the modules with fieldbus connector
- Two dowels for exact mounting of the module on the host board
- Metal blocks can easily modified for special customer requirements
- Front panel can be mounted on the metal blocks that the modules have always the same front size and covers the fieldbus connector
- Many modules are available in extended temperature specification (operating temperature range -20°C ... +65°C)
- COMX 52 modules and the COMX 51CA-RE\R module have address switches to set the bus address
- COMX 51 and COMX 52 modules offer a serial dual-port memory mode as interface to the host

CA and CN types of COMX modules

For the COMX family, Hilscher offers modules with angled or without fieldbus connectors:

- COMX CN: COMX modules without fieldbus respectively Ethernet connector
- COMX CA: COMX modules with angled fieldbus respectively Ethernet connector

Description of COMX modules

All COMX have a powerful processor and a complete fieldbus respectively Real-Time Ethernet interface including isolated drivers and the connector according to the standard.

All boards require only a single stabilized 3.3 V voltage. All other voltages are created by DC/DC converter on the COMX module.

The access to the COMX module is through the parallel dual-port memory which can be easily integrated as a static memory device. It has a non-multiplexed 8 or 16-bit data bus with several control lines to the host system. Between the COMX module and the host system it is possible to generate interrupts for data handling.

Alternatively, a serial dual-port memory based on SPI can be used as interface to the host system. Table 19 on page 35 lists the supported modes of COMX modules.

Generally the firmware and the configuration data are stored permanently in FLASH memory by loading the data through the dual-port memory.

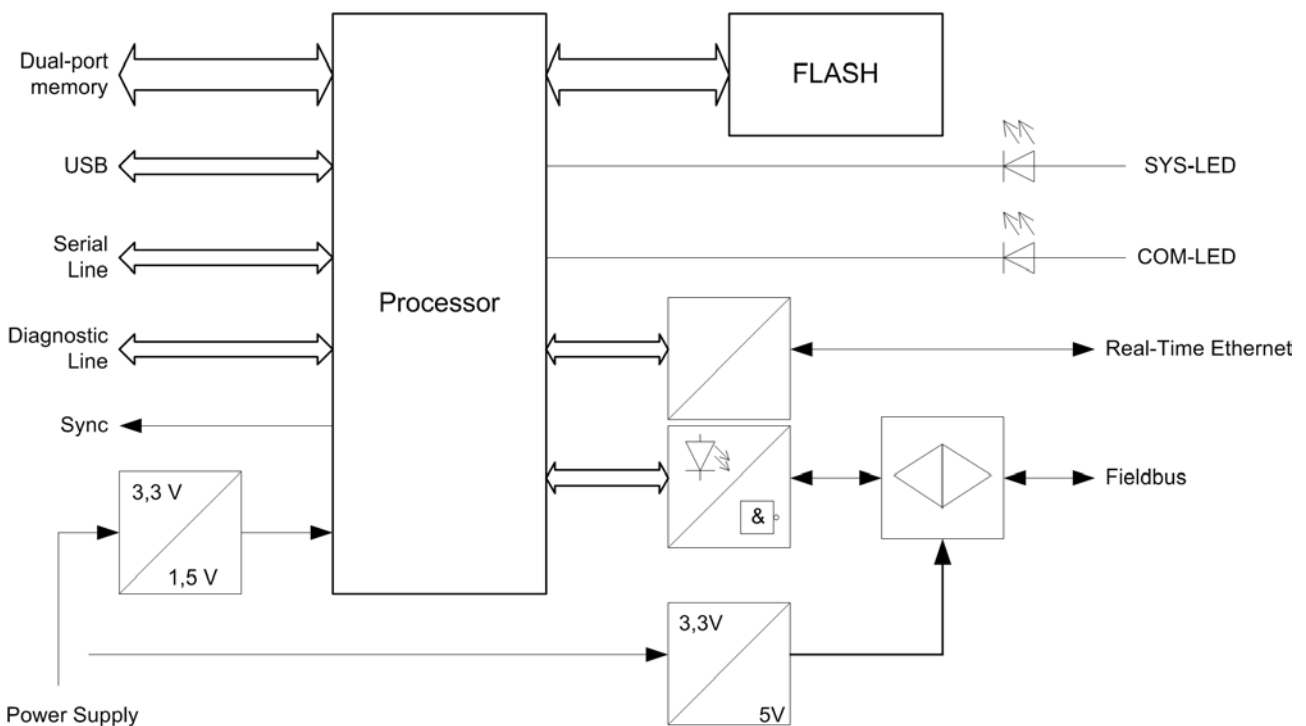

Figure 1: Block diagram of the COMX modules

1.5 Module names

The following table lists all COMX modules. The range of products has been expanded with COMX modules with netX 51 or with netX 52. As a result of this expansion, it was necessary to rename the existing COMX modules by adding '100' to the name, which indicates that netX 100 is used on the module respectively by adding '51/52' to the name, which indicates that netX 51/52 is used etc.

Communication system	Old module name	New module name
Real-Time Ethernet	COMX-CA-RE	COMX 100CA-RE
	COMX-CN-RE	COMX 100CN-RE
	-	COMX 51CA-RE
	-	COMX 51CA-REIR
	-	COMX 51CN-RE
CANopen Master	COMX-CA-COM	COMX 100CA-CO
	COMX-CN-COM	COMX 100CN-CO
CANopen Slave	COMX-CA-COS	COMX 100CA-CO
	COMX-CN-COS	COMX 100CN-CO
	-	COMX 52CA-COS
	-	COMX 52CN-COS
CC-Link Slave	-	COMX 52CA-CCS
	-	COMX 52CN-CCS
DeviceNet Master	COMX-CA-DNM	COMX 100CA-DN
	COMX-CN-DNM	COMX 100CN-DN
DeviceNet Slave	COMX-CA-DNS	COMX 100CA-DN
	COMX-CN-DNS	COMX 100CN-DN
	-	COMX 52CA-DNS
	-	COMX 52CN-DNS
PROFIBUS DP Master	COMX-CA-DPM	COMX 100CA-DP
	COMX-CN-DPM	COMX 100CN-DP
PROFIBUS DP Slave	COMX-CA-DPS	COMX 100CA-DP
	COMX-CN-DPS	COMX 100CN-DP
	-	COMX 52CA-DPS
	-	COMX 52CN-DPS

Table 4: comX modules – Old and new names

1.6 References to documents

This document refers to the following documents:

- [1] Hilscher Gesellschaft für Systemautomation mbH: Dual-Port Memory Interface Manual, netX based products, Revision 17, English, 2020.
- [2] Hilscher Gesellschaft für Systemautomation mbH: User Manual, comX, Communication Modules for Real-Time Ethernet and Fieldbus, Revision 11, English, 2021.
- [3] Hilscher Gesellschaft für Systemautomation mbH: Benutzerhandbuch, comX, Kommunikationsmodule für Real-Time Ethernet und Feldbus, Revision 11, German, 2021.
- [4] Hilscher Gesellschaft für Systemautomation mbH: Getting Started Guide, Serial Dual-Port Memory Interface with netX, Revision 6, English, 2018.
- [5] Hilscher Gesellschaft für Systemautomation mbH: Technical Data Reference Guide, netX 51/52, Revision 3, English, 2017.

Table 5: References to documents

2 Design-in - Mechanical aspects

2.1 Type of COMX modules

The following table gives an overview on the availability of the different COMX modules.

Module	Fieldbus / Protocol	Type	Connector
COMX 51			
COMX 51CA-RE,	Real-Time Ethernet	Slave	angled
COMX 51CA-RE\R	EtherCAT	Slave	angled
COMX 51CN-RE	Real-Time Ethernet	Slave	no
COMX 52			
COMX 52CA-COS	CANopen	Slave	angled
COMX 52CN-COS	CANopen	Slave	no
COMX 52CA-CCS	CC-Link	Slave	angled
COMX 52CN-CCS	CC-Link	Slave	no
COMX 52CA-DPS	PROFIBUS DP	Slave	angled
COMX 52CN-DPS	PROFIBUS DP	Slave	no
COMX 52CA-DNS	DeviceNet	Slave	angled
COMX 52CN-DNS	DeviceNet	Slave	no
COMX 100			
COMX 100CA-CO	CANopen	Master or Slave (depends on loaded firmware)	angled
COMX 100CN-CO	CANopen	Master or Slave (depends on loaded firmware)	no
COMX 100CA-DN	DeviceNet	Master or Slave (depends on loaded firmware)	angled
COMX 100CN-DN	DeviceNet	Master or Slave (depends on loaded firmware)	no
COMX 100CA-DP	PROFIBUS DP	Master or Slave (depends on loaded firmware)	angled
COMX 100CN-DP	PROFIBUS DP	Master or Slave (depends on loaded firmware)	no
COMX 100CA-RE	Real-Time Ethernet	Master or Slave (depends on loaded firmware)	angled
COMX 100CN-RE	Real-Time Ethernet	Master or Slave (depends on loaded firmware)	no

Table 6: Available comX modules

The following figures show the position of connector X1 and X2.

CA Types

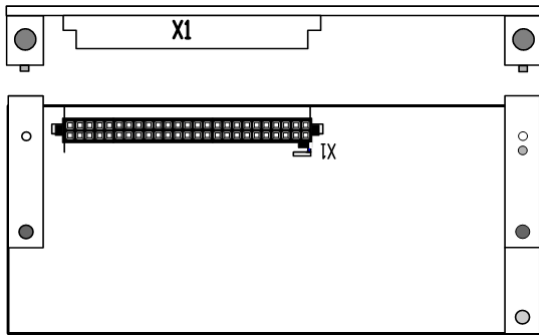

Figure 2: COMX CA type - Connector X1

CN Types

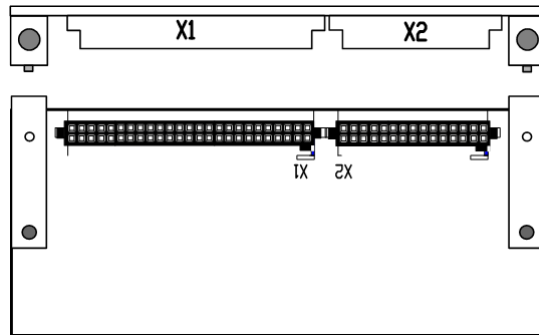

Figure 3: COMX CN type - Connectors X1 and X2

2.2 Mechanical dimensions

2.2.1 Common mechanical dimensions for COMX modules

After mounting the COMX-CA Module parallel at a basis board the rotary switches, LEDs and the fieldbus connector are on the top side and are angled to the basis board. The edge of all front elements are in one layer which is 2.5 mm ahead of the edge of printed circuit board of the COMX module.

The COMX-CN Module has to be used if the mechanical dimensions or order of the LEDs, switches and fieldbus connector does not fit. In that case you have to place these components directly on the motherboard and feed the signals to the connector X2 of the COMX-CN Module.

Note: Please take care on the isolation distance, because the optical isolation interface is on the module!
Especially for 12 MBit PROFIBUS, the distance should be as small as possible.
For Ethernet the signal traces should run parallel and should have the same length.
Please refer at the fieldbus standards for further information!

2.2.2 Mechanical dimensions of COMX modules

The COMX module has a board size of 30 x 70 mm.

The maximum height of the components at the top side of the printed circuit board is 14.0 mm including the fieldbus connector which is also the component defining the height of the CA type. For the CN type, the parts defining the height of these modules are the DC/DC converter and the transformer.

In order to assure the long-term availability of the modules, Hilscher claims the right to perform a redesign if necessary due to changes in availability of components and to exchange these components by similar ones which might differ in their dimensions.

In detail, the current minimum space requirements are given by the following table right below.

COMX module	Minimum required space on top of top side of the printed circuit board
CA type	14 mm
CN type	9 mm

Table 7: Minimum required space on top of top side of the printed circuit board

However, in order

- to be able to exchange a COMX module against any other type of COMX module later
- and to be sure that future COMX modules which might have been affected by a redesign will fit under any circumstances
- and to avoid thermal problems,

we urgently recommend to obey the following rule:

Note: Keep the space of 14.0 mm above the top side of the COMX modules free.

At the bottom side the maximum height is 4.0 mm, therefore you have 2.5 mm space for components on the host board below the module. The power dissipation in that area should be less than 330 mW!

For further module development please reserve additional 10 mm space behind the module. There are a few larger fieldbus interfaces which do not fit on the small board space. In that case a second printed circuit board will be mounted on top of the module and the 10 mm space is necessary for the connection with flex stripe between these boards.

The general dimensions of the COMX modules are shown on the following drawings:

Drawing	Title	Page
M0203764	General Mechanical dimension of COMX-CA-XXX	15
M0204664	Mechanical dimension of COMX-CN-XXX	16
M0300638	Mechanical dimension of light pipe of COMX 51/52/100CA-XXX	17
M0600177	Mechanical dimension of cover and connector of COMX 51/100CA-RE and COMX 51CA-RE\ R	18
M1100134	Mechanical dimension of cover and connector of COMX 51CA-RE\ R	19
M1100133	Mechanical dimension of cover and connector of COMX 52CA-XXX (Fieldbus)	20
M0900164	Mechanical dimension of cover and connector of COMX 100CA-XXX (Fieldbus)	21

Table 8: Mechanical dimensions (Drawings overview)

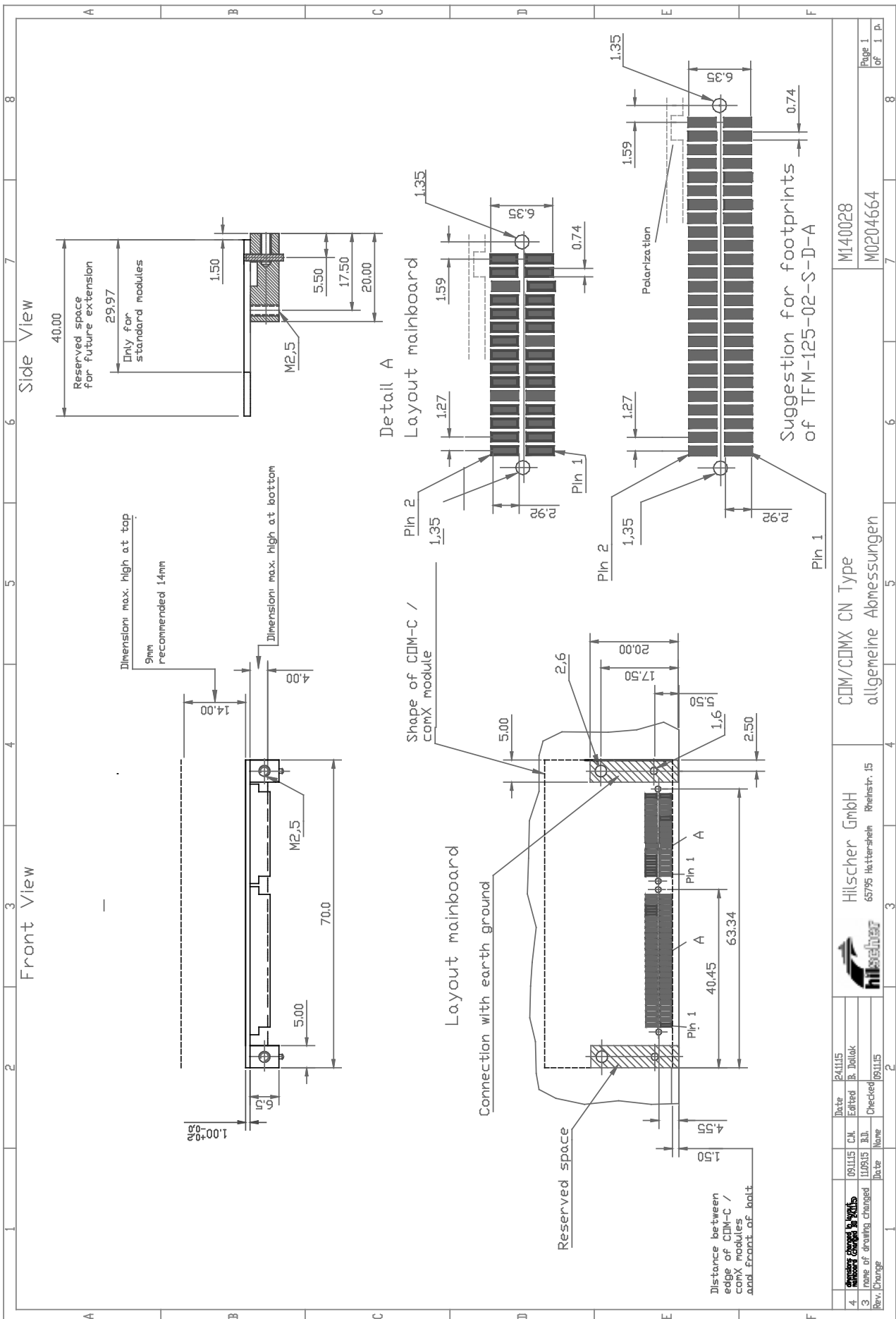

Date: 24.11.15		Date: 09.11.15		Date: 09.11.15	
Edited: B. Djalak		Edited: B.D.		Checked: B.D.	
Name: B. Djalak		Name: B.D.		Name: B.D.	
Rev. Change: 4		Rev. Change: 3		Rev. Change: 2	
Hilscher GmbH 65795 Hattersheim Rheinstr. 15		Hilscher GmbH 65795 Hattersheim Rheinstr. 15		Hilscher GmbH 65795 Hattersheim Rheinstr. 15	
COMX/COMX CN Type		COMX/COMX CN Type		COMX/COMX CN Type	
allgemeine Abmessungen		allgemeine Abmessungen		allgemeine Abmessungen	
M140028		M140028		M140028	
M0204664		M0204664		M0204664	
Page 1		Page 1		Page 1	
of 1 p.		of 1 p.		of 1 p.	

Figure 5: Mechanical dimension of COMX-CN-XXX

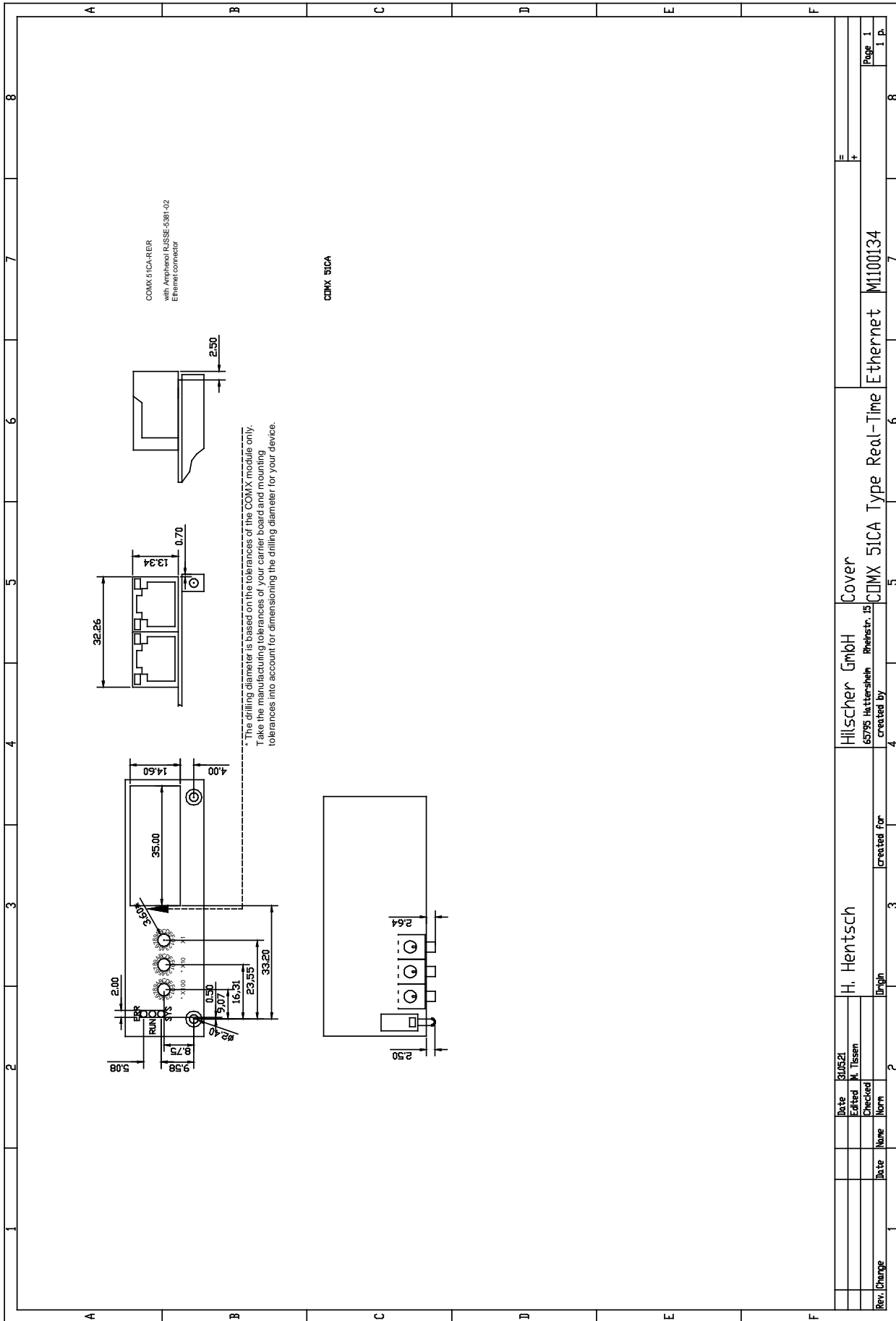

Figure 8: Mechanical dimension of cover and connector of COMX 51CA-REVR

2.3 Type of connector

The connector X1 for the host interface is a 50 pins SMT female type with a grid of 1.27 mm.

The COMX modules of the CN series have an additional Fieldbus connector X2 with 30 pins of the same family.

The connector of the motherboard is the corresponding male type and can be ordered as follows:

In Germany FJH die Steckverbinder GmbH
 Hinter dem Turm 7
 D-55286 Wörrstadt
 Germany
 Tel. +49 (0) 67 32 / 93 27 -0
 Fax +49 (0) 67 32 / 93 27 -27
 Web: www.fjh.de
 Email: info@fjh.de

50 pin. Box header 127 KA - 050 SB
 30 pin. Box header 127 KA - 030 SB

World Wide SAMTEC
 www.samtec.com

Cheaper version

50 pin. Connector TFM - 125 - 02 - S - D - A TFC - 125 - 02 - F - D - A
 30 pin. Connector TFM - 115 - 02 - S - D - A TFC - 115 - 02 - F - D - A

Note: Datasheet of SAMTEC TFM connector see next page.
 Please notice that the polarization of X1 and X2 is opposite to Pin 1!

The Fieldbus connector on the module is defined by the Fieldbus standard as followed:

Fieldbus	Connector	Vendor
CANopen	9 pin, DSub, male	div. Vendor
DeviceNet	5 pin, COMBICON, male Grid 5.08 mm	i.e. PHOENIX Contact MSTBA2,5/5-5,08G-AU
Ethernet	8 pin, RJ45, female	div. Vendor
PROFIBUS	9 pin, DSub, female	div. Vendor
CC-Link	5 pin, COMBICON, male Grid 5.08 mm	i.e. PHOENIX Contact MSTBA2,5/5-G-AU

Table 9: Connector types

Please use the same type of connector on the motherboard if you have chosen the COMX CN type module.

2.3.1 Storage and contact reliability of host-side connector

For the host-side connectors used in the comX communication modules (Samtec Types SFC-115-T2-L-D-A-K-TR and SFC-125-T2-L-D-A-K-TR), the following applies concerning storage stability and long-term immunity against contact failure:

- Hilscher only uses highly reliable connectors in the comX modules. The supplier of the connector warrants a minimum expected storage time of 5 years without any loss of spring tension when the connectors have been mounted. According to its general terms and conditions, Hilscher assures this warranted storage time to you.
- In order to preserve the spring tension and to improve the immunity against contact failure of the host-side connectors, the following storage conditions are recommended:
 - Storage in dry package such as ESD bags which additionally can be heat-sealed.
 - Alternatively: Controlled storage at a temperature of max. 25 °C and 50 % relative humidity.

2.4 Mounting of COMX modules

The COMX module has two metal blocks for mounting. This guarantees a robust mechanical construction and a solid connection to earth ground for the Fieldbus connector.

- The metal block close to the Fieldbus connector must be connected to PE (= Protective Earth).
- The metal block close to the LEDs is not connected to the comX circuit and can be connected to PE, too.

The metal blocks also define the distance between the module and host board. They are connected together with M2.5 screws.

On the front side of the metal blocks there are a M2.5 thread to mount a front panel directly on the module. This allows to have the same cutting in the device housing for all types of Modules.

- Use fine technology that means six-mil-wide (150 μm) tracks

Note: With this you have the possibility to get out between the pads.
For the power tracks. You can insert a via straight in the pad.
To prevent a soldering problem. Please use a fine via (drill 0.2 mm).

- Place a via between board edge and connector pad

Note: There is 1 mm space between the connector and the board edge, where you can place a 'normal' via (drill 0.3 mm) to feed the signals to the bottom side.

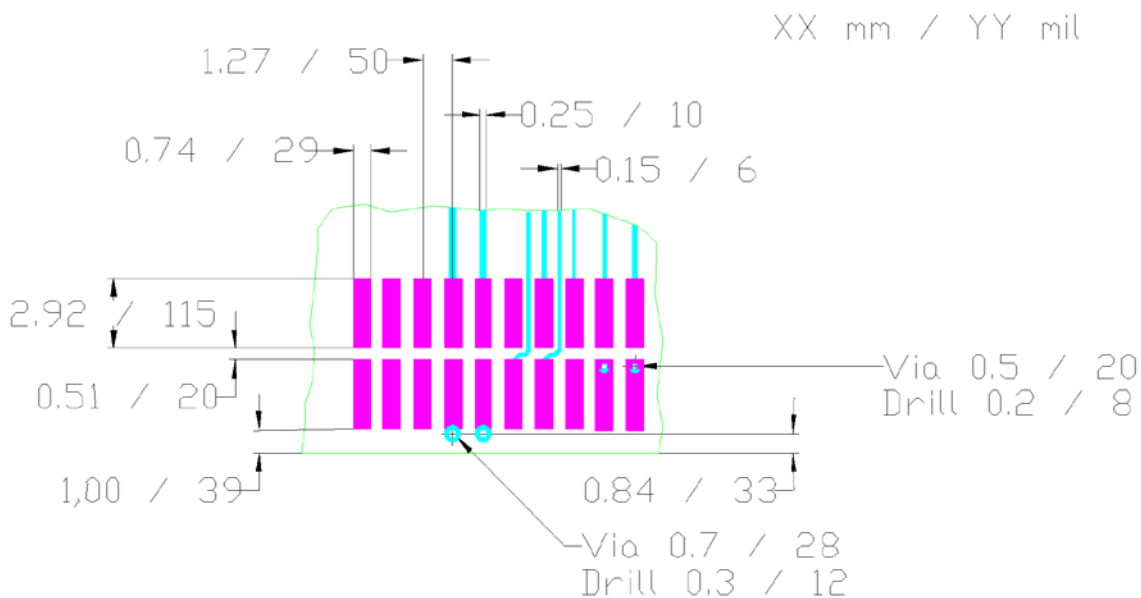

Figure 12: How to layout the signals at the connectors X1 and X2

Three types of metal bolts are used. The following table lists the usage for each COMX module.

COM	Type	Left Side	Right Side
COMX 51CA	RE, RE\R	COM-CA-B20X5	COM-CA-B31,5X5
COMX 51CN	RE	COM-CA-B20X5	COM-CA-B20X5
COMX 52CA	COS, DNS, DPS	COM-CA-B20X5	COM-CA-B24X5
	CCS	COM-CA-B20X5	COM-CA-B20X5
COMX 52CN	CCS, COS, DNS, DPS	COM-CA-B20X5	COM-CA-B20X5
COMX 100CA	CO, DN, DP, CC	COM-CA-B20X5	COM-CA-B24X5
	RE	COM-CA-B20X5	COM-CA-B31,5X5
COMX 100CN	COM, COS, DNM, DNS, DPM, DPS, RE	COM-CA-B20X5	COM-CA-B20X5

Table 10: Usage of bolt for COMX modules

The drawings for the bolts are shown on the following drawings:

Drawing	Title	Page
M0100084	Mechanical dimension of bolt COM-CA-B20X5	27
M0600121	Mechanical dimension of bolt COM-CA-B31,5X5	28
M0900102	Mechanical dimension of bolt COM-CA-B24X5	29

Table 11: Drawings of bolts (Overview)

The drawing for an assembled bolt is shown on the following drawing:

Drawing	Title	Page
M0200402	Mechanical dimension how to assemble COM-CA-XXX on the motherboard	30

Table 12: Drawings of assembled bolt (Overview)

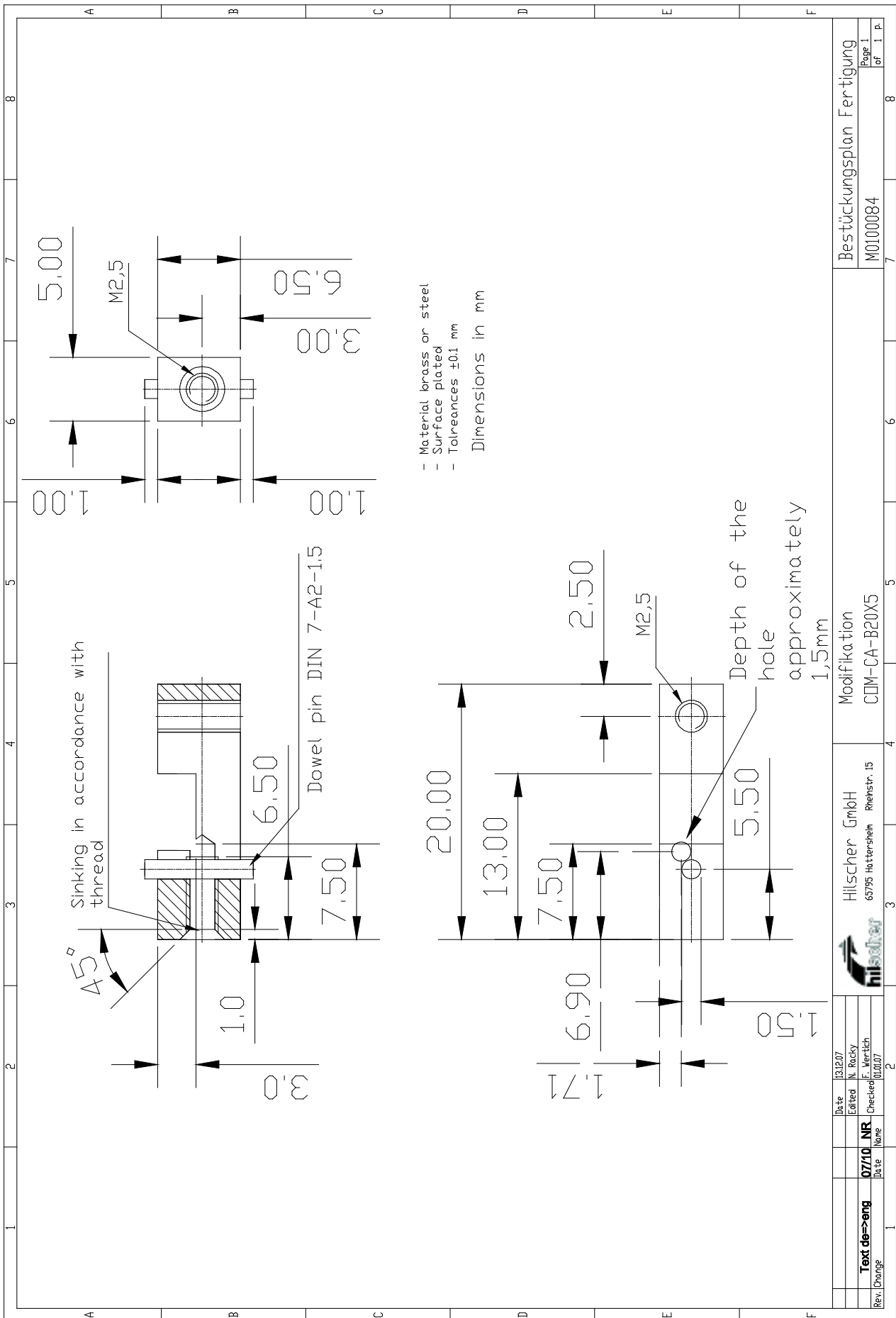

Figure 13: Mechanical dimension of Bolt COM-CA-B20X5

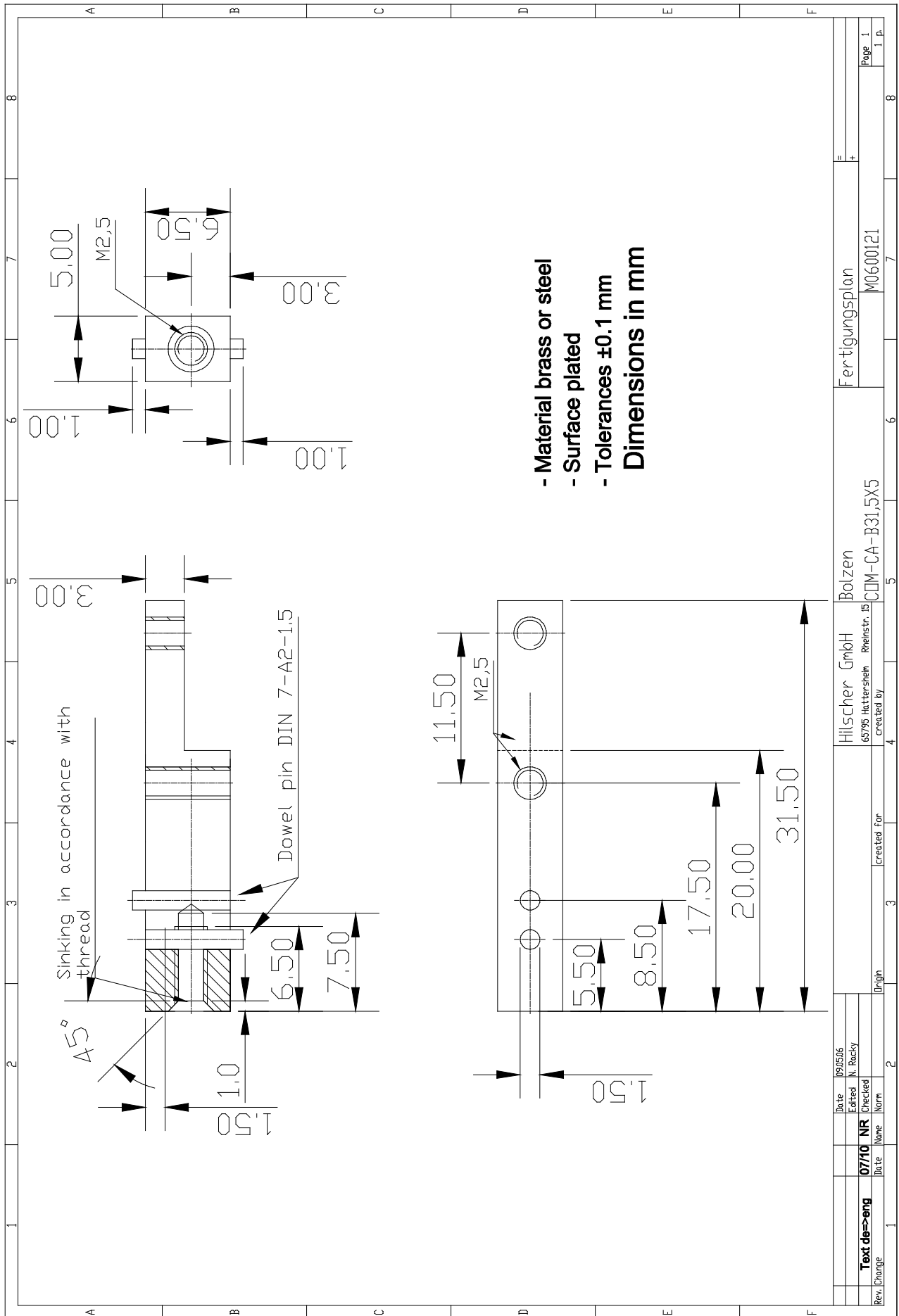
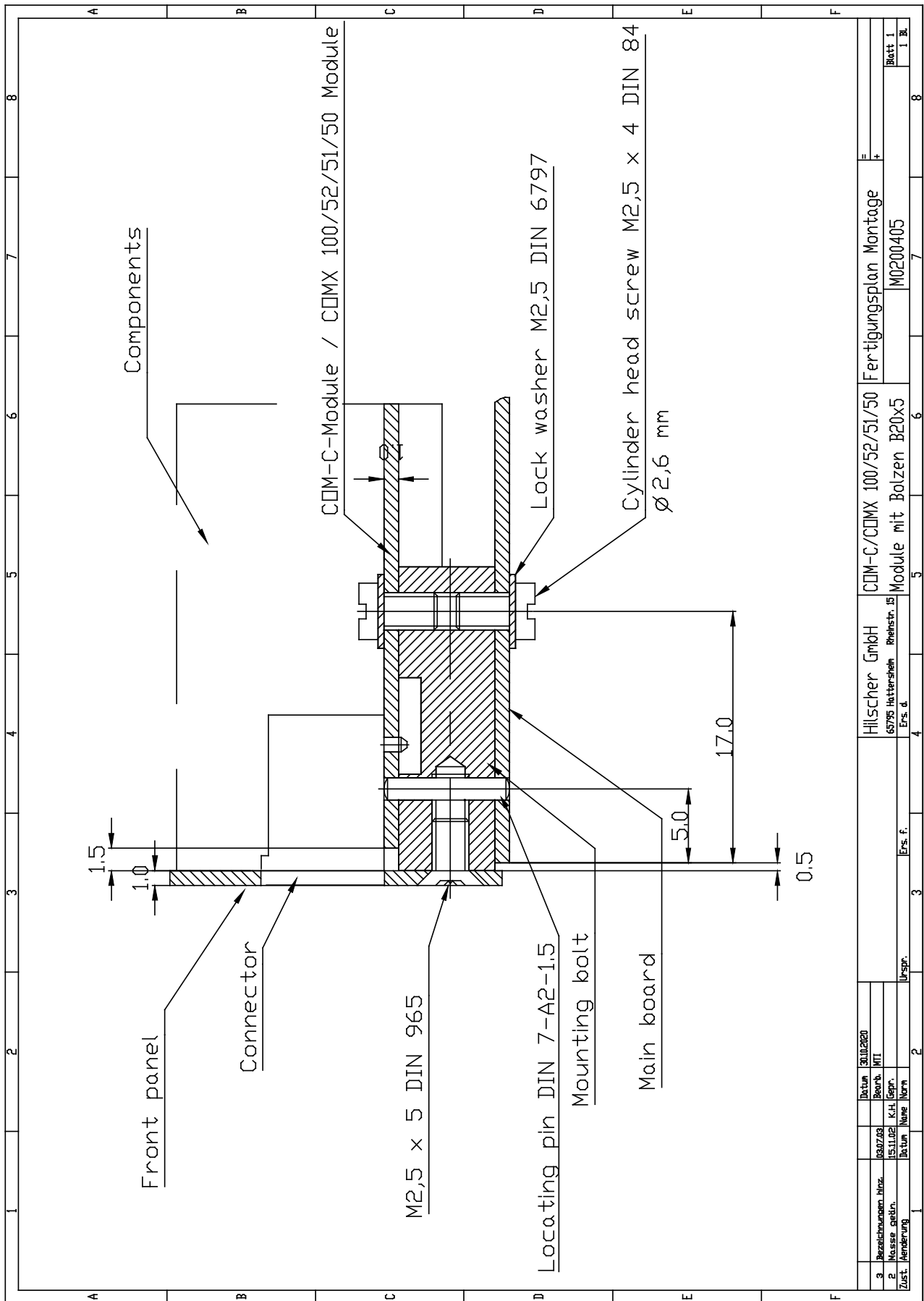

Figure 14: Mechanical dimension of Bolt COM-CA-B31,5X5



2.5 Material recommendation for the faceplate

For achieving good emission and immunity behavior of your device under construction into which the COMX module is integrated, we urgently recommend to use metal as material for the covering faceplate. Do not use plastics!

2.6 Designation of the COMX module

Each COMX module has a matrix code label. A matrix label contains 3 items:

1. Part number/Order number
2. Hardware Revision
3. Serial number

The figure shows part number 1521.416, hardware revision 3 and serial number 00200.



Figure 17: Example matrix code label of COMX modules

The label is normally glued on top of the main processor.

2.7 Meaning of the address switch

2.7.1 PROFIBUS DP Slave

COMX 52CA-DPS and COMX 52CN-DPS

The following table shows the meaning of the address switch for COMX 52.

PROFIBUS DP Slave	Station address	
		
	Station address = Value * 10 + Value * 1	
Value range for Station address: 0 ... 99	0 ... 9 = valid address	0 ... 9 = valid address

Table 13: Meaning of the address switch of COMX 52CA-DPS and COMX 52CN-DPS

Example: For station address 12 set the left address switch to 1 and the right address switch to 2.

2.7.2 CANopen Slave

COMX 52CA-COS and COMX 52CN-COS

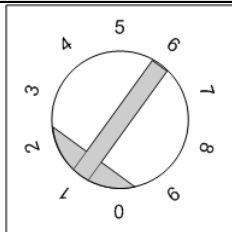
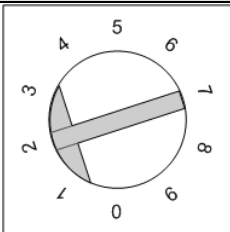
The following table shows the meaning of the address switch for COMX 52.

CANopen Slave	Node address	
		
Node address =	Value * 10	+ Value * 1
Value range for node address: 0 ... 99	0 ... 9 = valid address	0 ... 9 = valid address

Table 14: Meaning of the address switch of COMX 52CA-COS and COMX 52CN-COS

Example: For node address 12 set the left address switch to 1 and the right address switch to 2.

2.7.3 DeviceNet Slave

COMX 52CA-DNS and COMX 52CN-DNS

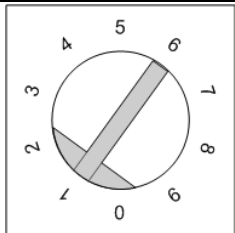
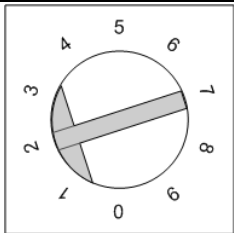
The following table shows the meaning of the address switch for COMX 52.

DeviceNet Slave	MAC ID	
		
MAC ID =	Value * 10	+ Value * 1
Value range for MAC ID: 0 ... 63	0 ... 6 = valid address 7, 8, 9 = invalid address, error	0 ... 9 = valid address

Table 15: Meaning of the address switch of COMX 52CA-DNS and COMX 52CN-DNS

Example: For MAC ID 12 set the left address switch to 1 and the right address switch to 2.

2.7.4 CC-Link Slave

COMX 52CA-CCS and COMX 52CN-CCS

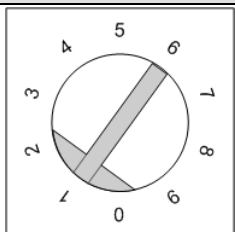
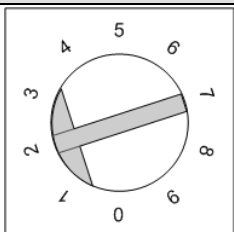
The following table shows the meaning of the address and baud rate switches for COMX 52.

CC-Link Slave	Station address		Baud rate
			
	Station address = Value * 10 + Value * 1		
Value range for Station address: 1 ... 64	0 ... 6 = valid address 7, 8, 9 = invalid address, error	0, 1, ..., 8, 9 = valid address	0 = 156 kBaud 1 = 625 kBaud 2 = 2,5 MBaud 3 = 5 MBaud 4 = 10 MBaud 5 ... 9 = Invalid, error

Table 16: Meaning of the address and baud rate switch of COMX 52CA-CCS and COMX 52CN-CCS

Example: For station address 12 set the left switch to 1 and the middle switch to 2. For baud rate 156 kBaud set the right switch to 0.

Depending on the configuration parameter 'Number of stations', the value range for station address is:

Number of stations	Value range for station address
1	1 ... 64
2	1 ... 63
3	1 ... 62
4	1 ... 61

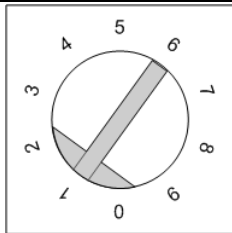
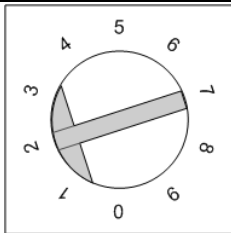
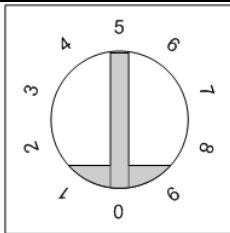
Table 17: Value range for station address depending on number of stations

2.7.5 EtherCAT Slave

COMX 51CA-RE\R

The following table shows the meaning of the address switches for COMX 51CA-RE\R.

EtherCAT Slave	Station address		
	 <p data-bbox="389 600 608 629">Address switch X100</p>	 <p data-bbox="745 600 963 629">Address switch X10</p>	 <p data-bbox="1101 600 1319 629">Address switch X1</p>
	<p data-bbox="376 638 1441 678">Station address = Value * 256 + Value * 16 + Value * 1</p>		
<p data-bbox="151 678 376 770">Value range for Station address: 1 ... 4095</p>	<p data-bbox="376 678 732 770">0, 1, ..., E, F = valid address</p>	<p data-bbox="732 678 1088 770">0, 1, ..., E, F = valid address</p>	<p data-bbox="1088 678 1441 770">0, 1, ..., E, F = valid address</p>

Table 18: Meaning of the address switch of COMX 51CA-RE\R

Example: For station address 288 (corresponding to 0x120) set the left switch to 1, the middle switch to 2 and the right switch to 0.

3 Design-in - Electrical aspects

3.1 Host interface

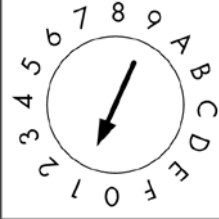
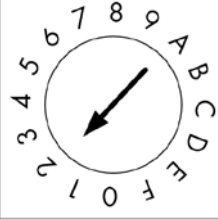
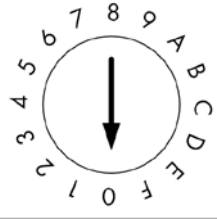
Attention! All COMX modules have an operation voltage of 3.3 V which reduces the power consumption. Therefore the voltage levels of the signals have to be not higher than 3.3 V otherwise the module will be damaged.

The next sections show an overview of the signal pin assignment of the system connector.

3.1.1 Host interface overview: Dual-port memory sizes and modes

The following table lists the dual-port memory size and the supported dual-port memory modes for the different COMX modules.

Module	Fieldbus / Protocol	Dual-port memory size	Parallel mode	Serial mode
COMX 51				
COMX 51CA-RE	Real-time Ethernet Slave	16 KByte	yes	yes
COMX 51CA-RE\R	Real-time Ethernet Slave		yes	yes
COMX 51CN-RE	Real-time Ethernet Slave		yes	yes
COMX 52				
COMX 52CA-COS	CANopen Slave	8 KByte	yes	yes
COMX 52CA-CCS	CC-Link Slave		yes	yes
COMX 52CA-DPS	PROFIBUS DP Slave		yes	yes
COMX 52CA-DNS	DeviceNet Slave		yes	yes
COMX 52CN-COS	CANopen Slave		yes	yes
COMX 52CN-CCS	CC-Link Slave		yes	yes
COMX 52CN-DPS	PROFIBUS DP Slave		yes	yes
COMX 52CN-DNS	DeviceNet Slave		yes	yes
COMX 100				
COMX 100CA-CO	CANopen Master or Slave	16 KByte	yes	-
COMX 100CN-CO	CANopen Master or Slave		yes	-
COMX 100CA-DN	DeviceNet Master or Slave		yes	-
COMX 100CN-DN	DeviceNet Master or Slave		yes	-
COMX 100CA-DP	PROFIBUS DP Master or Slave		yes	-
COMX 100CN-DP	PROFIBUS DP Master or Slave		yes	-
COMX 100CA-RE	Real-time Ethernet Master or Slave		yes	-
COMX 100CN-RE	Real-time Ethernet Master or Slave		yes	-

Table 19: Dual-port memory size and supported modes of the comX modules

In general, the COMX module supports 14 address lines and thus a dual-port memory size of 16 KB.

In case of the COMX 52 modules even only the lowest 8 KB of the available address space are supported by the firmware. So not all address lines need to be used. Unused address lines should be equipped with a pull-down resistor of 560 Ω.

The following table explains the available possibilities:

Modules	Host address space	Connect to	Address lines to be connected with 560 Ω pull-down
COMX 52	8 KByte	A0..A12	A13
COMX 52/51/100	16 KByte	A0..A13	none

Table 20: Possibilities for usage of dual-port memory

3.1.2 Host interface: Parallel or serial dual-port memory mode

3.1.2.1 COMX 100

COMX 100 Modules support one host interface mode: parallel dual-port memory mode.

How to set the 8 or 16 bit data width in parallel dual-port memory mode

The data width of the dual-port memory can be set to 8 or 16 bit. The data width is set at DPM_SIRQn during the start-up phase.

- A high signal at DPM_SIRQn sets the data width of 8 bit: pin is unconnected.
- A low signal at DPM_SIRQn sets the data width of 16 bit: 680 Ω pull-down resistor.

Note: COMX 100 modules require a **power cycle** (hardware reset) to switch from 8 bit data width to 16 bit data width and vice versa, because the data width is read and set during boot of netX only.

3.1.2.2 COMX 51 and COMX 52

COMX 51 and COMX 52 modules support two host interface modes:

- parallel dual-port memory mode and the
- serial dual-port memory mode.

This can be configured by the level of the mode setting signal, which is evaluated during start-up phase of the module.

How to set the host interface mode

Parallel Dual-Port Memory Mode

- A high signal at DPM_DIRQn during start-up phase activates the dual-port memory mode.
- The data width of the dual-port memory can be set to 8 or 16 bit. The data width is set at DPM_SIRQn during the start-up phase.
 - A high signal at DPM_SIRQn sets the data width of 8 bit: pin is unconnected.
 - A low signal at DPM_SIRQn sets the data width of 16 bit: 680 Ω pull-down resistor.

Note: COMX 51 and COMX 52 modules require a **reset** (software reset) to switch from 8 bit data width to 16 bit data width and vice versa, because the data width is read and set during start up only. Alternatively a power cycle (hardware reset) can be used to switch the data width.

Serial Dual-Port Memory Mode

- A low signal at DPM_DIRQn activates the serial dual-port memory mode (via a 680 Ω pull-down resistor). Pin DPM_SIRQn: let the input open.

Signals DPM_DIRQn and DPM_SIRQn have a pull-up resistor of 4,7 kΩ on the COMX 51 or 52 Module.

Important: Never drive the host interface mode signal (DPM_DIRQn). Instead, operation with pull-down and pull-up resistors is recommended.

3.1.3 COMX pin assignment of the system bus connector X1 – Parallel mode

X1	Pin	Signal	COMX 51, PAD type	COMX 52, PAD type	COMX 100, PAD type	Symbol	Type
	1	Word Interface, active low	IOD9	IOD9	IO18C	DPM_SIRQn	LVTTTL Input
	2	Bus high enable, active low	IOU9	IOU9	IO18C	DPM_BHEn	LVTTTL Input
	3	Data line 15	IOU9	IOU9	IO18C	DPM_D15	LVTTTL Input / Output
	4	Data line 14	IOU9	IOU9	IO18C	DPM_D14	LVTTTL Input / Output
	5	Data line 13	IOU9	IOU9	IO18C	DPM_D13	LVTTTL Input / Output
	6	Data line 12	IOU9	IOU9	IO18C	DPM_D12	LVTTTL Input / Output
	7	Data line 11	IOU9	IOU9	IO18C	DPM_D11	LVTTTL Input / Output
	8	Data line 10	IOU9	IOU9	IO18C	DPM_D10	LVTTTL Input / Output
	9	Data line 9	IOU9	IOU9	IO18C	DPM_D9	LVTTTL Input / Output
	10	Data line 8	IOU9	IOU9	IO18C	DPM_D8	LVTTTL Input / Output
	11	Ground				GND	
	12	Power Supply				+3V3	
	13	Transmit Data, Serial line			IOD6	UART1_TXD	LVTTTL Output
	14	Receive Data, Serial line			IOD6	UART1_RXD	LVTTTL Input
	15	Request to Send, Serial line & SYNC0	IODS6		IOD6	UART1_RTSn/ SYNC0	LVTTTL Output / SYNC Input / Output Signal XC3_IO0 (Note 1, 2)
	16	Clear to Send, Serial line & SYNC1	IODS6		IOD6	UART1_CTSn/ SYNC1	LVTTTL Input / SYNC Input / Output Signal XC3_IO1 (Note 1, 2)
	17	USB positive, Diagnostic line	USB	USB	USB	USB+	USB
	18	USB negative, Diagnostic line	USB	USB	USB	USB-	USB
	19	Receive Data, Diagnostic line	IODS6		IOD6	UART0_RXD	LVTTTL Input
	20	Transmit Data, Diagnostic line	IODS6		IOD6	UART0_TXD	LVTTTL Output
	21	Reset, active low			IO18C	DPM_RESETn	LVTTTL Input; 10 kΩ pull up at COMX
	22	Busy, active low	IOU9		IO18C	DPM_BUSYn	LVTTTL Output
	23	During operation: Interrupt, active low COMX 51 and COMX 52 at start-up: Host mode selection	IOU9	IOU9	IO18C	DPM_DIRQn	During operation: LVTTTL Output At start-up: LVTTTL Input

Table 21: COMX pin assignment of the system bus connector X1- Parallel DPM mode (Part 1)

X1	Pin	Signal	COMX 51, PAD type	COMX 52, PAD type	COMX 100 PAD type	Symbol	Type
	24	Read, active low	IOU9	IOU9	IO18C	DPM_RDn	LVTTTL Input
	25	Write, active low	IOU9	IOU9	IO18C	DPM_WRn	LVTTTL Input
	26	Chip select, active low	IOU9	IOU9	IO18C	DPM_CSn	LVTTTL Input
	27	Address line 13	IOU9	IOU9	IO18C	DPM_A13	LVTTTL Input
	28	Address line 12	IOU9	IOU9	IO18C	DPM_A12	LVTTTL Input
	29	Address line 11	IOU9	IOU9	IO18C	DPM_A11	LVTTTL Input
	30	Address line 10	IOU9	IOU9	IO18C	DPM_A10	LVTTTL Input
	31	Address line 9	IOU9	IOU9	IO18C	DPM_A9	LVTTTL Input
	32	Address line 8	IOU9	IOU9	IO18C	DPM_A8	LVTTTL Input
	33	Address line 7	IOU9	IOU9	IO18C	DPM_A7	LVTTTL Input
	34	Address line 6	IOU9	IOU9	IO18C	DPM_A6	LVTTTL Input
	35	Address line 5	IOU9	IOU9	IO18C	DPM_A5	LVTTTL Input
	36	Address line 4	IOU9	IOU9	IO18C	DPM_A4	LVTTTL Input
	37	Address line 3	IOU9	IOU9	IO18C	DPM_A3	LVTTTL Input
	38	Address line 2	IOU9	IOU9	IO18C	DPM_A2	LVTTTL Input
	39	Address line 1	IOU9	IOU9	IO18C	DPM_A1	LVTTTL Input
	40	Address line 0	IOU9	IOU9	IO18C	DPM_A0	LVTTTL Input
	41	Data line 7	IOU9	IOU9	IO18C	DPM_D7	LVTTTL Input / Output
	42	Data line 6	IOU9	IOU9	IO18C	DPM_D6	LVTTTL Input / Output
	43	Data line 5	IOU9	IOU9	IO18C	DPM_D5	LVTTTL Input / Output
	44	Data line 4	IOU9	IOU9	IO18C	DPM_D4	LVTTTL Input / Output
	45	Data line 3	IOU9	IOU9	IO18C	DPM_D3	LVTTTL Input / Output
	46	Data line 2	IOU9	IOU9	IO18C	DPM_D2	LVTTTL Input / Output
	47	Data line 1	IOU9	IOU9	IO18C	DPM_D1	LVTTTL Input / Output
	48	Data line 0	IOU9	IOU9	IO18C	DPM_D0	LVTTTL Input / Output
	49	Ground				GND	
	50	Power Supply				+3V3	

Table 22: COMX pin assignment of the system bus connector X1 – Parallel DPM mode (Part 2)

Note	Information
1	Support of SYNC signals depends on the functionality of the used firmware. See <i>SYNC signals</i> on page 63 for details.
2	SYNC0 and SYNC1 are available on COMX 100CA-RE, COMX 100CN-RE, and COMX 51CA-RE only.

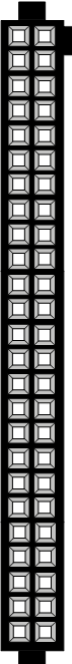
Table 23: Notes for COMX pin assignment of the System Bus Connector X1

3.1.4 COMX pin assignment of the system bus connector X1 – Serial mode

The following table is valid for COMX 51 and COMX 52 Modules only and if the serial dual-port memory mode is active.

X1	Pin	Signal	COMX 51 PAD type	COMX 52 PAD type	Symbol	Type
	1	reserved	IOD9	IOD9	reserved	Note 3
	2	reserved	IOU9	IOU9	reserved	Note 3
	3	reserved	IOU9	IOU9	reserved	Note 3
	4	reserved	IOU9	IOU9	reserved	Note 3
	5	reserved	IOU9	IOU9	SPM_SIRQn	LVTTTL Output, Note 4
	6	reserved	IOU9	IOU9	SPM_DIRQn	LVTTTL Output, Note 4
	7	Clock	IOU9	IOU9	SPM_CLK	LVTTTL Input
	8	Chip select, active low	IOU9	IOU9	SPM_CSn	LVTTTL Input
	9	Master Out Slave In	IOU9	IOU9	SPM_MOSI	LVTTTL Input
	10	Master In Slave Out	IOU9	IOU9	SPM_MISO	LVTTTL Output
	11	Ground			GND	
	12	Power Supply			+3V3	
	13	Transmit Data, Serial line	IODS6	IODS6	UART1_TXD	LVTTTL Output
	14	Receive Data, Serial line	IODS6	IODS6	UART1_RXD	LVTTTL Input
	15	Request to Send, Serial line & SYNC0	IODS6	IODS6	UART1_RTSn / SYNC0	LVTTTL Output / SYNC Output Signal XC3_IO0 (Note 1, 2)
	16	Clear to Send, Serial line & SYNC1	IODS6	IODS6	UART1_CTSn / SYNC1	LVTTTL Input / SYNC Output Signal XC3_IO1 (Note 1, 2)
	17	USB positive, Diagnostic line	USB	USB	USB+	USB
	18	USB negative, Diagnostic line	USB	USB	USB-	USB
	19	Receive Data, Diagnostic line	IODS6	IODS6	UART0_RXD	LVTTTL Input
	20	Transmit Data, Diagnostic line	IODS6	IODS6	UART0_TXD	LVTTTL Output
	21	Reset, active low			DPM_RESETh	LVTTTL Input; 10 kΩ pull up
	22	reserved			reserved	Note 3
	23	Host mode selection at start-up	IOU9	IOU9	DPM_DIRQn	At start-up: LVTTTL Input
	24	reserved	IOU9	IOU9	reserved	Note 3
	25	reserved	IOU9	IOU9	reserved	Note 3
	26	reserved	IOU9	IOU9	reserved	Note 3

Table 24: COMX pin assignment of the system bus connector X1- Serial DPM mode COMX 51/COMX 52 (Part 1)

X1	Pin	Signal	COMX 51 PAD type	COMX 52 PAD type	Symbol	Type
	27	reserved	IOU9	IOU9	reserved	Note 3
	28	reserved	IOU9	IOU9	reserved	Note 3
	29	reserved	IOU9	IOU9	reserved	Note 3
	30	reserved	IOU9	IOU9	reserved	Note 3
	31	reserved	IOU9	IOU9	reserved	Note 3
	32	reserved	IOU9	IOU9	reserved	Note 3
	33	reserved	IOU9	IOU9	reserved	Note 3
	34	reserved	IOU9	IOU9	reserved	Note 3
	35	reserved	IOU9	IOU9	reserved	Note 3
	36	reserved	IOU9	IOU9	reserved	Note 3
	37	reserved	IOU9	IOU9	reserved	Note 3
	38	reserved	IOU9	IOU9	reserved	Note 3
	39	reserved	IOU9	IOU9	reserved	Note 3
	40	reserved	IOU9	IOU9	reserved	Note 3
	41	reserved	IOU9	IOU9	reserved	Note 3
	42	reserved	IOU9	IOU9	reserved	Note 3
	43	reserved	IOU9	IOU9	reserved	Note 3
	44	reserved	IOU9	IOU9	reserved	Note 3
	45	reserved	IOU9	IOU9	reserved	Note 3
	46	reserved	IOU9	IOU9	reserved	Note 3
	47	reserved	IOU9	IOU9	reserved	Note 3
	48	reserved	IOU9	IOU9	reserved	Note 3
	49	Ground			GND	
	50	Power Supply			+3V3	

Table 25: COMX pin assignment of the system bus connector X1 – Serial DPM Mode COMX 51/COMX 52 (Part 2)

Note	Information
1	Support of SYNC signals depends on the functionality of the used firmware. See <i>SYNC signals</i> on page 63 for details.
2	SYNC0 and SYNC1 are available on COMX 100CA-RE, COMX 100CN-RE, and COMX 51CA-RE only.
3	External wiring: Pin unconnected
4	Not supported

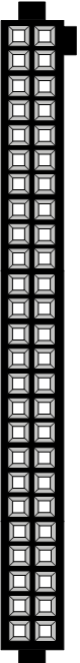
Table 26: Notes for COMX pin assignment of the system bus connector X1

3.1.5 PAD type explanation

Symbol	Description
I	Input
O	Output
Z	Output is tri-state-able or open drain
S	Input provides Schmitt trigger
U	Internal pull-up 50 k (I2C pins: pull-up 5k)
D	Internal pull-down 50 k
C	Internal clamping diodes to GND and VDDh
6	Output driver can source / sink 6 mA
9	Output driver can source / sink 9 mA
18	Output driver can source / sink 18 mA
XTAL	Crystal input or output
USB	USB pad
PHY	PHY pad
ANA	Analog pin
PWR	1.5V (Core) or 3.3V (I/O)
GND	Digital ground (0V)
APWR	Analog power (1.5V or 3.3V)
AGND	Analog ground (0V)

Table 27: PAD type explanation

Schematic view of netX pad types

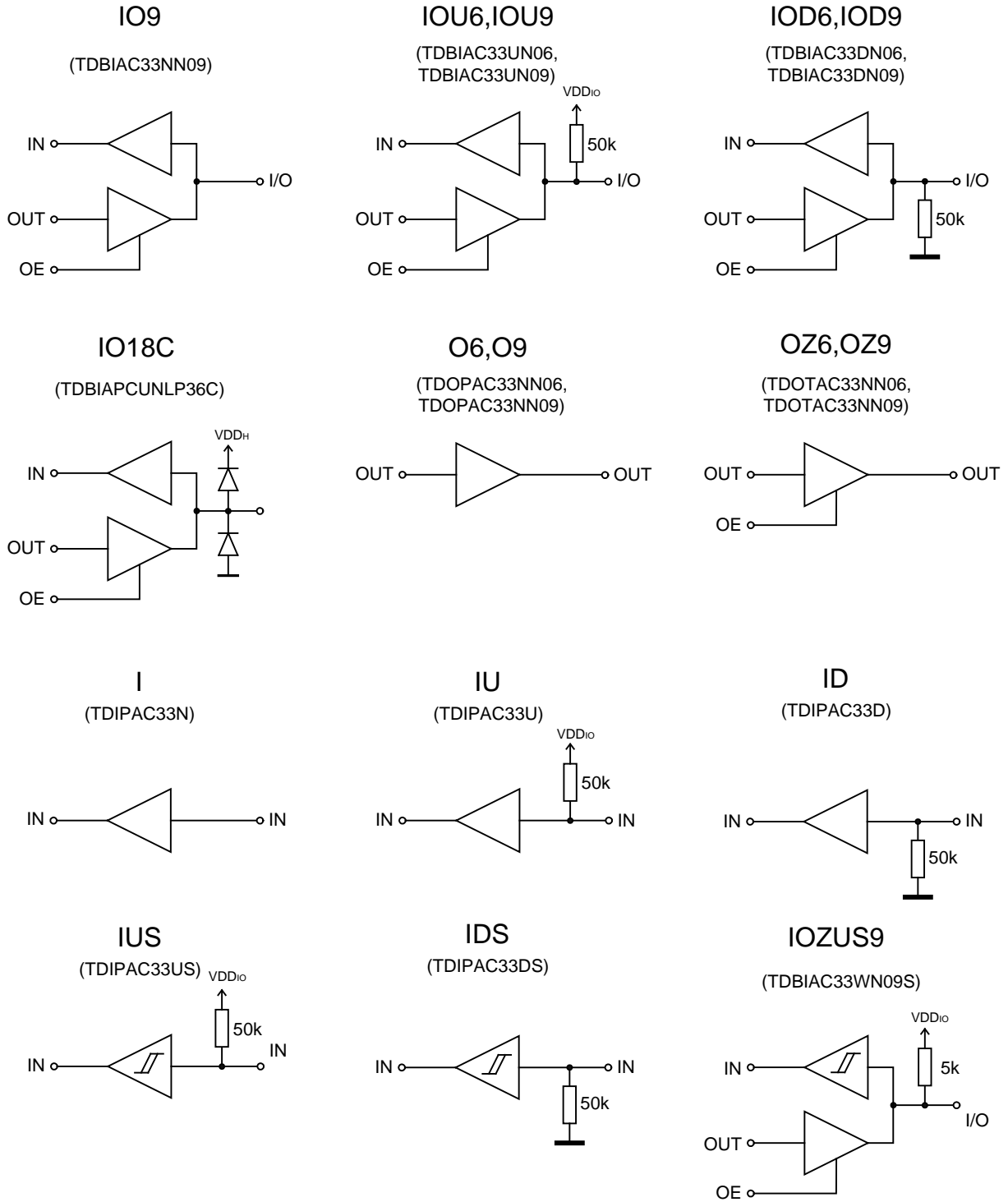

Figure 18: Schematic view of netX pad types

3.1.6 Signal overview and pin assignment of the fieldbus connector X2 on COMX CN

3.1.6.1 Fieldbus connector X2 for CC-Link Slave

Fieldbus connector X2 for COMX 52CN-CCS

X2	Pin	Signal	Symbol	Type	Pin at fieldbus connector COMBICON 5-pin
	1				
	2	Receive Driver Enable	RDENn	6 mA Output	Note 1
	3				
	4	CC-Link, Transmission period signal	SDGATEON	6 mA Output	Note 1
	5				
	6	CC-Link, Transmission Data	SD	6 mA Output	Note 1
	7				
	8	CC-Link, Received Data (channel 1)	RD1	TTL Input	Note 1
	9				
	10				
	11				
	12				
	13	L RUN-LED, STA, Cathode green LED	STAn	6 mA Output	
	14	SYS-LED, RUN, Cathode green LED	RUNn	6 mA Output	
	15	L ERR-LED, ERR, Cathode red LED	ERRn	6 mA Output	
	16	SYS-LED, RDY, Cathode yellow LED	RDYn	6 mA Output	
	17	Ground	GND		
	18	Power Supply	+3.3 V		
	19	Peripheral IO	PIO	LVTTTL Input / Output	
	20	Don't use - needed for isolation			
	21	Don't use - needed for isolation			
	22				
	23				
	24				
	25				
	26	CC-Link, Data A	DA		1
	27	CC-Link, Data B	DB		2
	28	CC-Link, Data Ground	DG		3
	29	CC-Link, Function Ground	FG		5
	30	CC-Link, Shield	SLD		4

Table 28: Fieldbus connector X2 for CC-Link Slave

Note	Information
1	LVTTTL Signals can only be used without the hardware interface on the COMX. Ask for special customer version.

Table 29: Notes for fieldbus connector X2 for CC-Link Slave

3.1.6.2 Fieldbus connector X2 for CANopen-Master/-Slave

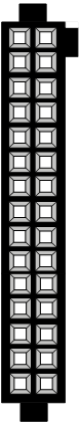
Fieldbus connector X2 for COMX 52CN-COS and COMX 100CN-CO

X2	Pin	Signal	Symbol	Type	Pin at Fieldbus connector DSub 9, male
	1				
	2				
	3				
	4				
	5				
	6				
	7	CAN, Receive Data	CAN_RX1	LVTTTL Input	Note 1
	8				
	9	CAN, Transmit Data	CAN_TX1	LVTTTL Output	Note 1
	10				
	11				
	12				
	13	COM-LED, STA, Cathode green LED	STAn	4 mA Output	Note 2
	14	SYS-LED, RUN, Cathode green LED	RUNn	4 mA Output	
	15	COM-LED, ERR, Cathode red LED	ERRn	4 mA Output	
	16	SYS-LED, RDY, Cathode yellow LED	RDYn	4 mA Output	
	17	Ground	GND		
	18	Power Supply	+3.3 V		
	19	Peripheral IO	PIO	LVTTTL Input / Output	
	20	Don't use - needed for isolation			
	21	Don't use - needed for isolation			
	22				
	23	CAN_H Bus line	CAN_H	ISO 11898	7
	24				
	25				
	26	CAN Ground	CAN_GND		3
	27				
	28				
	29	CAN_L Bus line	CAN_L	ISO 11898	2
	30				

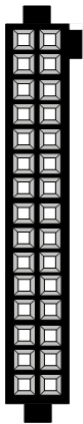

Table 30: Fieldbus connector X2 for CANopen-Master/-Slave

Note	Information
1	LVTTTL Signals can only be used without the hardware interface on the COMX. Ask for special customer version.
2	Green LED for COMX 100CN-CO

Table 31: Notes for fieldbus connector X2 for CANopen-Master/-Slave

3.1.6.3 Fieldbus Connector X2 for DeviceNet-Master/-Slave

Fieldbus connector X2 for COMX 52CN-DNS and COMX 100CN-DN

X2	Pin	Signal	Symbol	Type	Pin at Fieldbus connector COMBICON 5-pin
	1				
	2				
	3				
	4				
	5				
	6				
	7	CAN, Receive Data	CAN_RX1	LVTTTL Input	Note 1
	8				
	9	CAN, Transmit Data	CAN_TX1	LVTTTL Output	Note 1
	10				
	11	CAN, Power Fail	CAN_PF1	LVTTTL Input	Note 1
	12				
	13	MNS-LED, active low, Cathode green LED	MNS_CGn	4 mA Output	
	14	RUN-LED, RUN, Cathode green LED	RUNn	4 mA Output	
	15	MNS-LED, active low, Cathode red LED	MNS_CRn	4 mA Output	
	16	SYS-LED, RDY, Cathode yellow LED	RDYn	4 mA Output	
	17	Ground	GND		
	18	Power Supply	+3.3 V		
	19	Peripheral IO	PIO	LVTTTL Input / Output	
	20	Don't use - needed for isolation			
	21	Don't use - needed for isolation			
	22				
	23				
	24				
	25				
	26	Reference potential DeviceNet	V-		1
	27	CAN Low-Signal	CAN_L		2
	28	Shield	Drain		3
	29	CAN High-Signal	CAN_H		4
	30	+24V Power Supply DeviceNet	V+		5

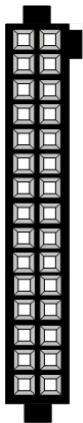

Table 32: Fieldbus connector X2 for DeviceNet-Master/-Slave

Note	Information
1	LVTTTL Signals can only be used without the hardware interface on the COMX. Ask for special customer version.

Table 33: Notes for fieldbus connector X2 for DeviceNet-Master/-Slave

3.1.6.4 Fieldbus Connector X2 for PROFIBUS-Master/-Slave

Fieldbus connector X2 for COMX 52CN-DPS and COMX 100CN-DP

X2	Pin	Signal	Symbol	Type	Pin at Fieldbus connector DSub-9, female
	1	PROFIBUS, Receive Data	PB_RX	LVTTTL Input	Note 1
	2				
	3	PROFIBUS, Transmit Data	PB_TX	LVTTTL Output	Note 1
	4				
	5	PROFIBUS, Enable Bus Driver	PB_ENB	LVTTTL Output	Note 1
	6				
	7				
	8				
	9				
	10				
	11				
	12				
	13	COM-LED, STA, Cathode green LED (COMX)	STAn	4 mA Output	Note 2
	14	SYS-LED, RUN, Cathode green LED	RUNn	4 mA Output	
	15	COM-LED, ERR, Cathode red LED	ERRn	4 mA Output	
	16	SYS-LED, RDY, Cathode yellow LED	RDYn	4 mA Output	
	17	Ground	GND		
	18	Power Supply	+3.3 V		
	19	Peripheral IO	PIO	LVTTTL Input / Output	
	20	Don't use - needed for isolation			
	21	Don't use - needed for isolation			
	22	Reference potential	DGND		5
	23	Control	CNTR-P	LVTTTL	4
	24				
	25	Receive / Send Data-N	RXD/TXD-N	RS 485	8
	26	Receive / Send Data-P	RXD/TXD-P	RS 485	3
	27				
	28				
	29	Positive power supply	VP	+ 5V	6
	30				

Table 34: Fieldbus connector X2 for PROFIBUS-Master/-Slave

Note	Information
1	LVTTTL Signals can only be used without the hardware interface on the COMX. Ask for special customer version.
2	Green LED for COMX 52CN-DPS and COMX 100CN-DP

Table 35: Notes for fieldbus connector X2 for PROFIBUS-Master/-Slave

3.1.6.5 Fieldbus Connector X2 for Real Time Ethernet

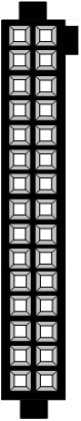
Fieldbus connector X2 for COMX 51CN-RE and COMX 100CN-RE:

X2	Pin	Signal	Symbol	Type	Pin at Fieldbus connector RJ45
	1	Link0-LED Cathode green, active low	LINK0_CGn	4 mA Output	
	2	TX/RX0-LED Cathode yellow, active low	TX/RX0_CYn	4 mA Output	
	3	Link1-LED Cathode green, active low	LINK1_CGn	4 mA Output	
	4	TX/RX1-LED Cathode yellow, active low	TX/RX1_CYn	4 mA Output	
	5	Transmit Data Positive Channel 0	CH0_TXP		1A
	6	Transmit Data Negative Channel 0	CH0_TXN		2A
	7	Transmit Center Tap Channel 0	CH0_TXC		4A
	8	Ground	GND		
	9	Receive Data Positive Channel 0	CH0_RXP		3A
	10	Receive Data Negative Channel 0	CH0_RXN		6A
	11	Receive Center Tap Channel 0	CH0_RXC		5A
	12	Ground	GND		
	13	Transmit Data Positive Channel 1	CH1_TXP		1B
	14	Transmit Data Negative Channel 1	CH1_TXN		2B
	15	Transmit Center Tap Channel 1	CH1_TXC		4B
	16	Ground	GND		
	17	Receive Data Positive Channel 1	CH1_RXP		3B
	18	Receive Data Negative Channel 1	CH1_RXN		6B
	19	Receive Center Tap Channel 1	CH1_RXC		5B
	20	Ground	GND		
	21	COM0-LED Cathode red, active low	COM0_CRn	4 mA Output	
	22	COM0-LED Cathode green, active low	COM0_CGn	4 mA Output	
	23	COM1-LED Cathode red, active low	COM1_CRn	4 mA Output	
	24	COM1-LED Cathode green, active low	COM1_CGn	4 mA Output	
	25	SYS-LED, RDY, Cathode yellow LED	RDYn	4 mA Output	
	26	SYS-LED, RUN, Cathode green LED	RUNn	4 mA Output	
	27	Peripheral IO	PIO	LVTTTL Input / Output	
	28	not connected			
	29	not connected			
	30	not connected			

Table 36: Fieldbus connector X2 for Real-Time Ethernet

The pin layout is designed to fit for a RJ45 connector with integrated transformers, LEDs and termination. Suggested part:

- 203313, ERNI or
- J8064D628ANL, Pulse

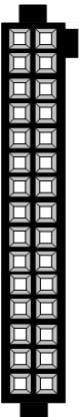
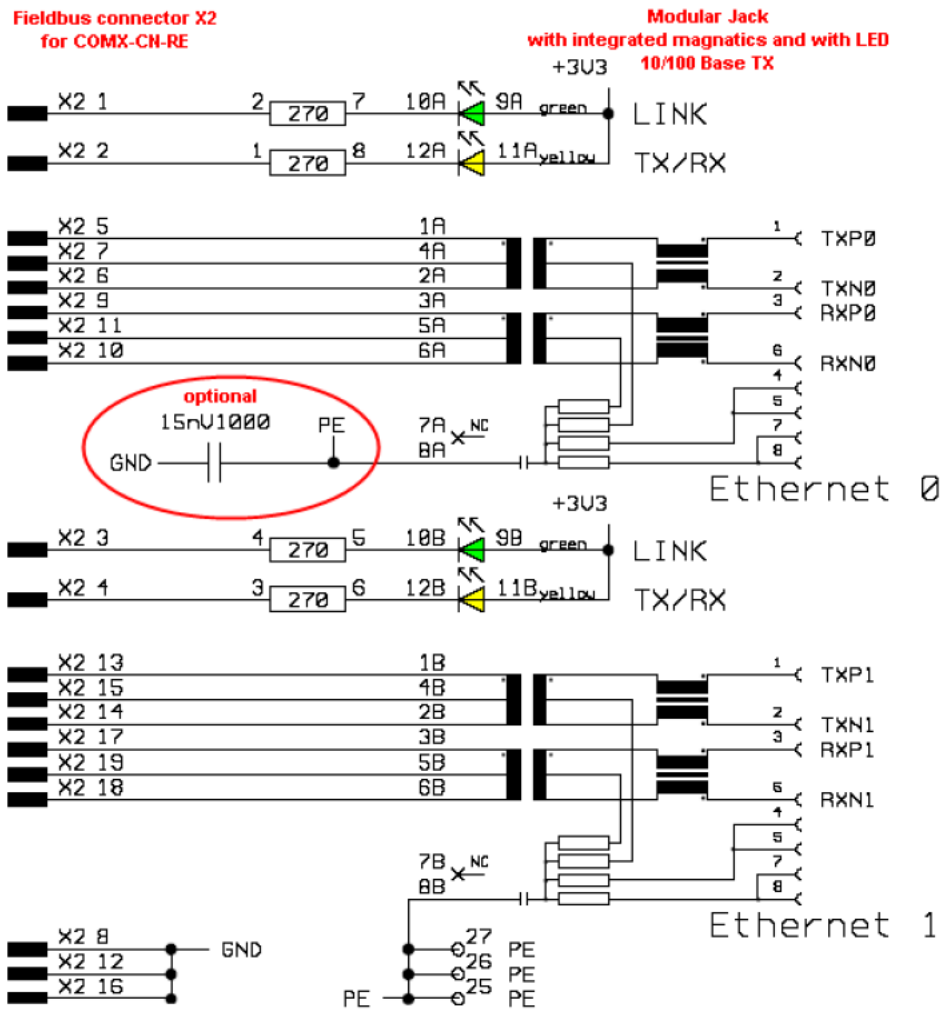

Figure 19: Ethernet connection COMX-CN-RE

The following figure shows the ERNI connector 203313 as an example:

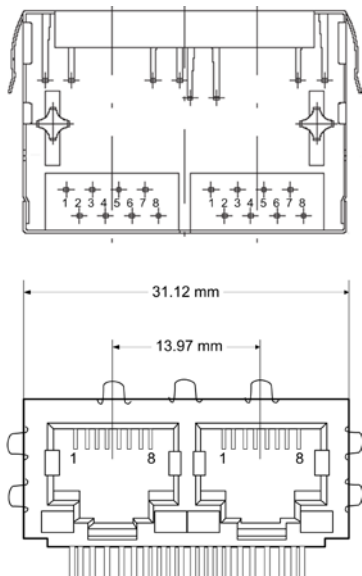

Figure 20: Ethernet connector example (ERNI 203313)

3.1.7 Common signals of the host interface

3.1.7.1 Power supply of the COMX modules

Only a single 3.3 V operation voltage is needed for the COMX module. The voltage must be regulated and can have a tolerance of $\pm 5\%$ (3.135 ... 3.465 V) and must be connected twice to the system bus connector X1. To avoid EMI problems we suggest using bypass capacitors in the power supply path. All other special voltages required on the COMX module are generated by on board DC/DC converter.

A watchdog circuit on all COMX modules supervises the voltage and the microprocessor. If the voltage decreases below the voltage reset level of typically 2.93 V (2.85 ... 3.00 V) the COMX module are hold in reset state. If the voltage exceeds the reset voltage threshold the COMX module will begin with the power up sequence. To avoid problems with the power supply we recommend using a voltage of 3.3 V. So the operation will be in the safe range of voltage operation area and short voltage drops, spikes and noise will not cause any reset conditions.

The maximum current depends on comX module type. For specific current values see section Technical data on page 64.

3.1.7.2 RESET signal

It is possible to reset the COMX module by the extra reset signal DPM_RESETn. For operation of the COMX module it is important to switch the signal DPM_RESETn to high level. Then the COMX module begins with the program execution and initialization. This power up time is different for each COMX module. Normally, the time is about less than two seconds. The COMX module is in reset state when the signal DPM_RESETn has a static low level. To reset the COMX module the DPM_RESETn signal must be low for more than 10 μs .

Note During Reset all signals of the dual-port memory are configured as inputs! The output level could be floating. If the host system needs a stable level a pull-up or pull-down resistor is required on the host board. The COMX has pull-up resistors on board for the output lines DPM_BUSYn and DPM_DIRQn.

3.1.8 Signals of the host interface – Parallel dual-port memory mode

3.1.8.1 The dual-port memory bus of COMX

The communication for all input and output data and control commands between the COMX and the host system are exchanged over the dual-port memory. The communication is not compatible to the COM-A/-B/-C devices. The address map of the dual-port memory is different.

From host system side, the dual-port memory looks like static RAM. The dual-port memory size of the COMX module depends on the COMX module type, see section *Host interface overview: Dual-port memory sizes and modes* on page 35. Only a few signals are used to control the access to the dual-port memory.

The maximum driving capability for the data lines is 8 mA (COMX 100) respectively 9 mA (COMX 51, COMX 52).

To avoid data loss through simultaneous access at the same memory cell, it is necessary to use the DPM_BUSYn signal. See section *BUSY line to the host system* on page 51.

Please refer to the special documents for the basic description of the data model and communication methods with devices based on the netX.

3.1.8.2 Address bus and data bus

These signal lines contain the address bus lines DPM_A0 up to DPM_A13 and data bus lines DPM_D0 up to DPM_D15 of the dual-port memory. The address and data lines are non-multiplexed. The address line DPM_A13 is only used at COMX devices to access a linear 16 KByte dual-port memory size.

The COMX devices support additional data bus lines to drive a 16 Bit data interface. If your host interface can support 16 Bit you should connect the DPM_SIRQn signal to ground. If not please let this uncommitted that 16 Bit modules will work in an 8 bit compatible mode.

In case of a 16 Bit system you have to generate the DPM_BHEn and DPM_A0 signal according the following table.

DPM_BHEn	DPM_A0	Function
0	0	word access
0	1	access high byte
1	0	access low byte
1	1	no access

Table 37: Function table of the 16 bit decode logic

3.1.8.3 Dual-port memory control lines

The user has to integrate the dual-port memory by mapping the memory space of the dual-port memory into the address range of the host system.

The access to the dual-port memory is handled over the control lines write DPM_WRn, read DPM_RDn and chip select DPM_CSn and could be used like standard static RAM. All signals are low active.

3.1.8.4 Interrupt line to the host system

The signal DPM_DIRQn can be used to generate an interrupt to the host system when the netX of the COMX module writes into the specific handshake cells of the dual-port memory. These cells are used for synchronization of the COMX modules and the host system and have handshake bits. For detailed information about the handshake bits refer to [1]. The interrupt will be cleared if the host reads the handshake cell that was written from the netX of the COMX module.

Important note:

In interrupt mode, when an 8 bit-host performs a read access to any of the 16 bit wide handshake registers, the netX releases the interrupt as soon as the high byte or the low byte was read. The read order (high byte first or low byte first) is irrelevant. An 8 bit-host shall use polling mode instead of interrupt mode.

Note: Signal DPM_DIRQn has on the module
a 4.7 kΩ pull-up resistor for COMX 51 and COMX 52
and a 10 kΩ pull-up resistor for COMX 100.

3.1.8.5 BUSY line to the host system

The signal BUSY_n is used to insert wait states into a current access from host system to a COMX module. When the signal is active the host must hold on the current transfer.

The timing diagram is described in section *Timing diagram parallel dual-port memory interface* on page 52.

Important Note 1: Avoid dual-port memory access errors

It is mandatory that the host CPU always uses the DPM_BUSY signal, otherwise this results in wrong data read from the dual-port memory or dual-port memory write accesses are being ignored.

This does not affect COMX51 and COMX52 modules!

- The maximum value for accesses cannot be specified.
 - For maximum performance, the DPM_BUSY signal must always be evaluated by the host CPU.
 - If you use a host CPU that cannot use the DPM_BUSY signal, then contact our technical support.
-

Note 2: The COMX has a 10 kΩ pull-up resistor on board for the output line DPM_BUSY_n

3.1.8.6 Interfacing to the dual-port memory for COMX

If you connect the host system to the dual-port memory of the COMX module you have to know some details of the functional working of the netX.

All accesses to the dual-port memory are synchronized to the netX clock and will be then translated into an internal access cycle. This needs some time. To manage the access timing the DPM_BUSY_n signal is generated to signal the host system to lengthen the current access cycle until the data could be written or the read data is valid.

An access cycle is started when the chip select line DPM_CS_n and read DPM_RD_n or write DPM_WR_n line are active. The address line must be stable during the complete cycle. It is not possible to switch the address lines during a cycle (no burst access). Moreover there must be a recovery time during two accesses.

For further details please refer the following timing diagrams.

3.1.8.7 Timing diagram parallel dual-port memory interface

The following diagram shows the timing for dual-port memory read access.

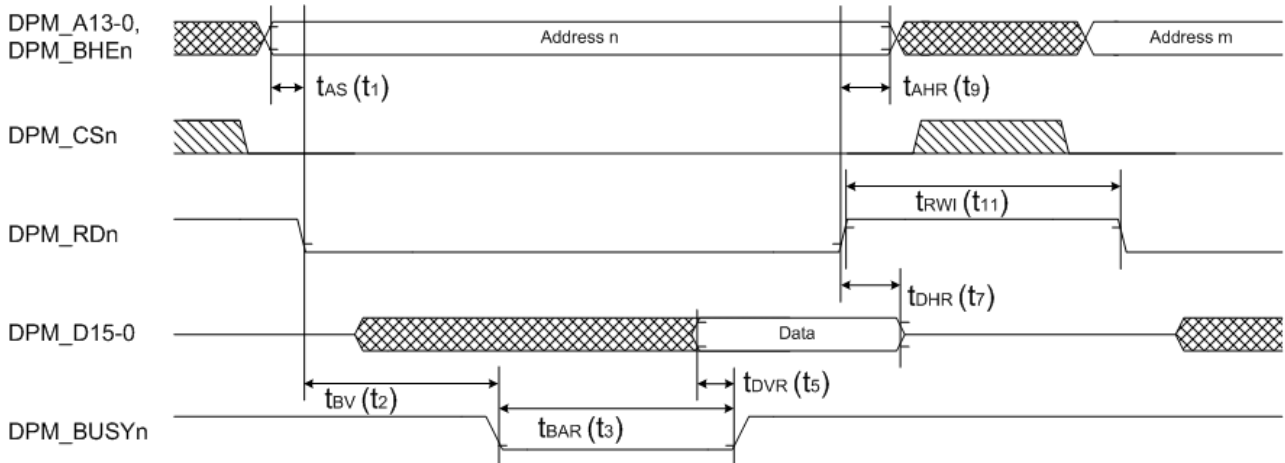

Figure 21: COMX timing diagram for read access

The following diagram shows the timing for dual-port memory write access.

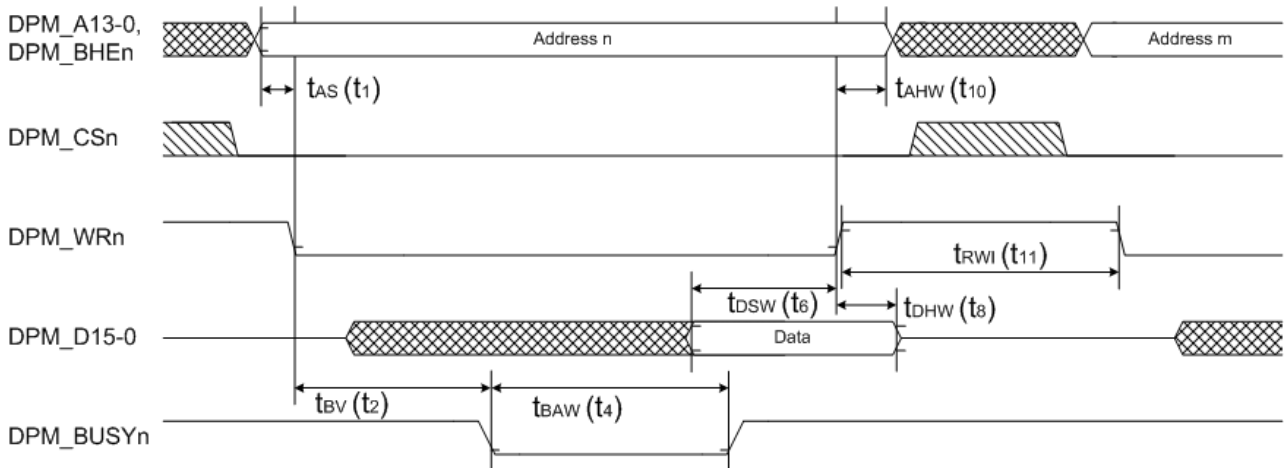

Figure 22: COMX timing diagram for write access

Description and values are on the next page.

The following table gives the values for the timing parameters for COMX 51 modules using the netX 51 chip, for COMX 52 modules using the netX 52 chip and for COMX 100 using the netX 100 chip. For exchangeability of COMX 51, COMX 52 and COMX 100 communication modules use the values of column **Common** of Table 38.

Symbol		Description	COMX 100 netX 100	COMX 51 netX 51	COMX 52 netX 52	Common
t ₁	t _{AS min.}	Minimum address setup time	0 ns	0 ns	0 ns	2 ns
t ₂	t _{BV max.}	Maximum Time from cycle start until BUSY _n signal is valid	30 ns	5,7 ns	5,7 ns	40 ns
t ₃	t _{BAR typ.}	Typical BUSY active time (read access) See note 2	80 ns	-	-	-
	t _{BAR max.}	Maximum BUSY active time (read access) See important note 1	-	68 ns	68 ns	-
t ₄	t _{BAW min.}	Minimum BUSY active time (write access)	0 ns	0 ns	0 ns	0 ns
	t _{BAW max.}	Maximum BUSY active time (write access) See important note 1	-	68 ns	68 ns	-
t ₅	t _{DVR min.}	Minimum Time between valid data bus signals and rising edge of BUSY _n signal	5 ns	7,8 ns	7,8 ns	5 ns
t ₆	t _{DSW min.}	Minimum setup time for write data	25 ns	12.8 ns	12.8 ns	25 ns
t ₇	t _{DHR min.}	Minimum read data hold time	0 ns	2.1 ns	2.1 ns	0 ns
t ₈	t _{DHW min.}	Minimum hold time for write data	0 ns	2.8 ns	2.8 ns	2.8 ns
t ₉	t _{AHR min.}	Minimum address hold time	0 ns	0 ns	0 ns	0 ns
t ₁₀	t _{AHW min.}	Minimum address hold time	0 ns	2.9 ns	2.9 ns	2.9 ns
t ₁₁	t _{RWI}	Minimum inactive time for RD _n or WR _n	10 ns	12.5 ns	12.5 ns	12.5 ns

Table 38: Symbols for COMX timing diagram for read and write access

Important Note 1:

Avoid dual-port memory access errors

It is mandatory that the host CPU always uses the DPM_BUSY_n signal, otherwise this results in wrong data read from the dual-port memory or dual-port memory write accesses are ignored. This does not affect COMX51 und COMX52!

- The maximum value for accesses cannot be specified.
- For maximum performance, the DPM_BUSY_n signal must always be evaluated by the host CPU.
- If you use a host CPU that cannot use the DPM_BUSY_n signal, then contact our technical support.

Note 2: The value for t_{BAR typ.} (t_{3 typ.}) depends on the used firmware/application on the netX.

Note 3: DPM_BHE_n is only used for 16 bit interface.

3.1.8.8 Integration of COMX module into a host system

It is possible to connect the COMX module to an 8 or 16 Bit data bus. For the 16 Bit interface selection it is necessary to connect the Word Interface Mode line DPM_SIRQn to a low level. If this line is left open the COMX devices will work with an 8 Bit interface like the COM devices.

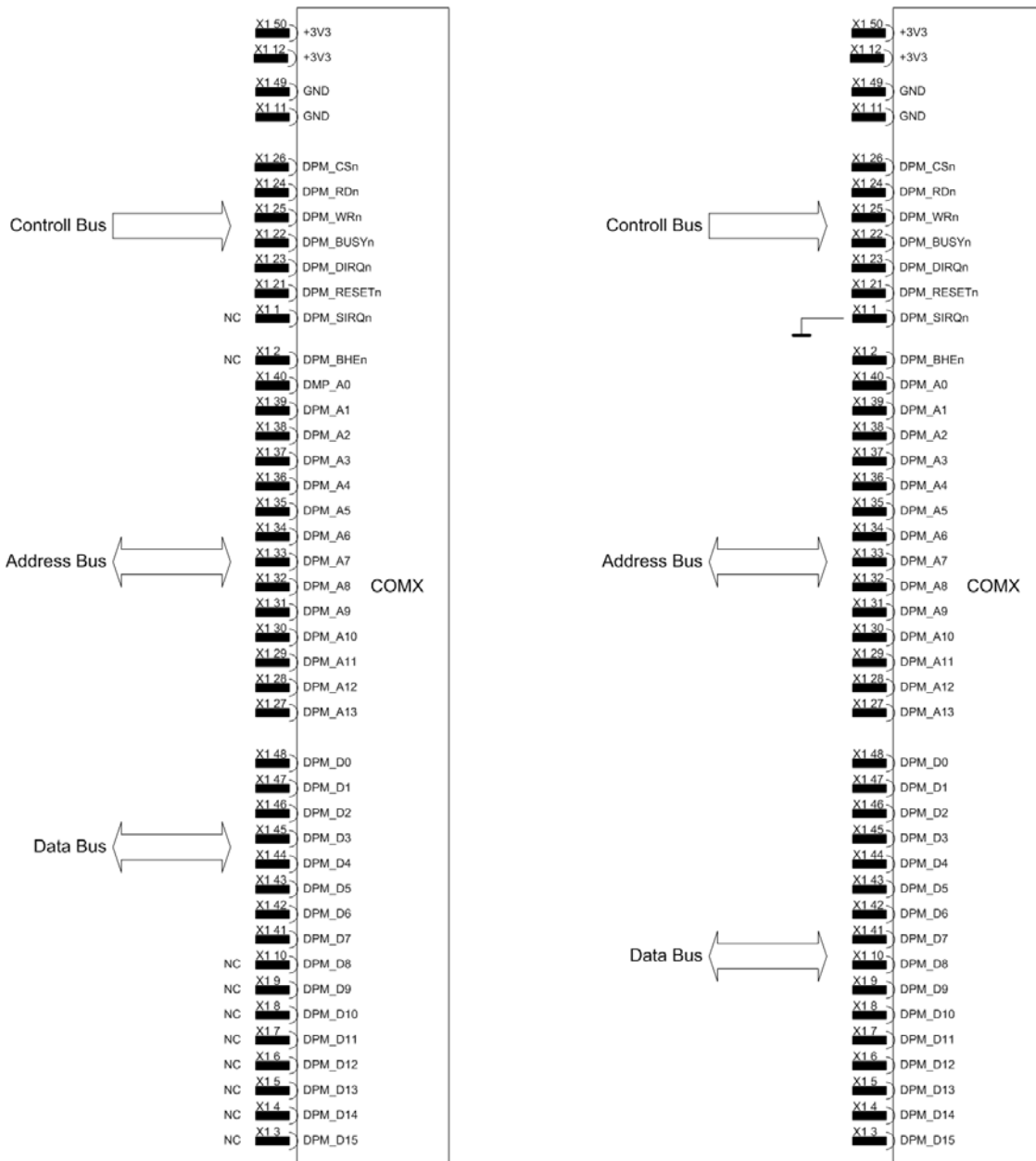

Figure 23: Interface with 8-bit data bus - Interface with 16-bit interface

DPM_BHE _n	DPM_A0	Function
0	0	word access D[15:0]
0	1 (high)	high byte access D[15:8]
1	0 (low)	low byte access D[7:0]
1	1	no access, illegal

Table 39: Function table of decode logic

3.1.9 Signals of the host interface – Serial dual-port memory mode

The COMX 51 and COMX 52 modules offer an SPI Slave interface which will be used for serial access to the dual-port memory of the COMX. The general connection of the serial dual-port memory to any SPI capable host CPU is shown in the following figure.

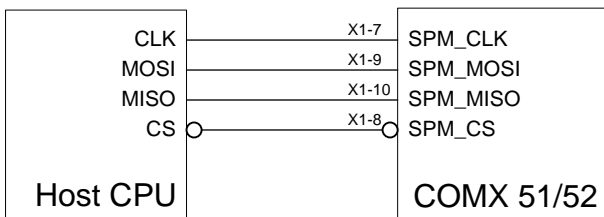

Figure 24: Serial dual-port memory interface

Table 24 lists the pin assignment of the serial dual-port memory interface at the system bus connector X1.

The default SPI mode is mode 3, CPOL = 1 and CPHA = 1.

Timing diagram serial dual-port memory interface

To access the dual-port memory of the COMX 51 and COMX 52 modules, see the timing diagram in section *Serial Mode IO Timing* in [5], pages 265 - 266.

Software implementation and protocol

For information about the software implementation and the protocol see section *Host Software Implementation* and section *Serial DPM Protocol Description* in [4].

3.2 Fieldbus interface

Figure 25 shows the connections of the pins of X2 and the pins of the Fieldbus connector.

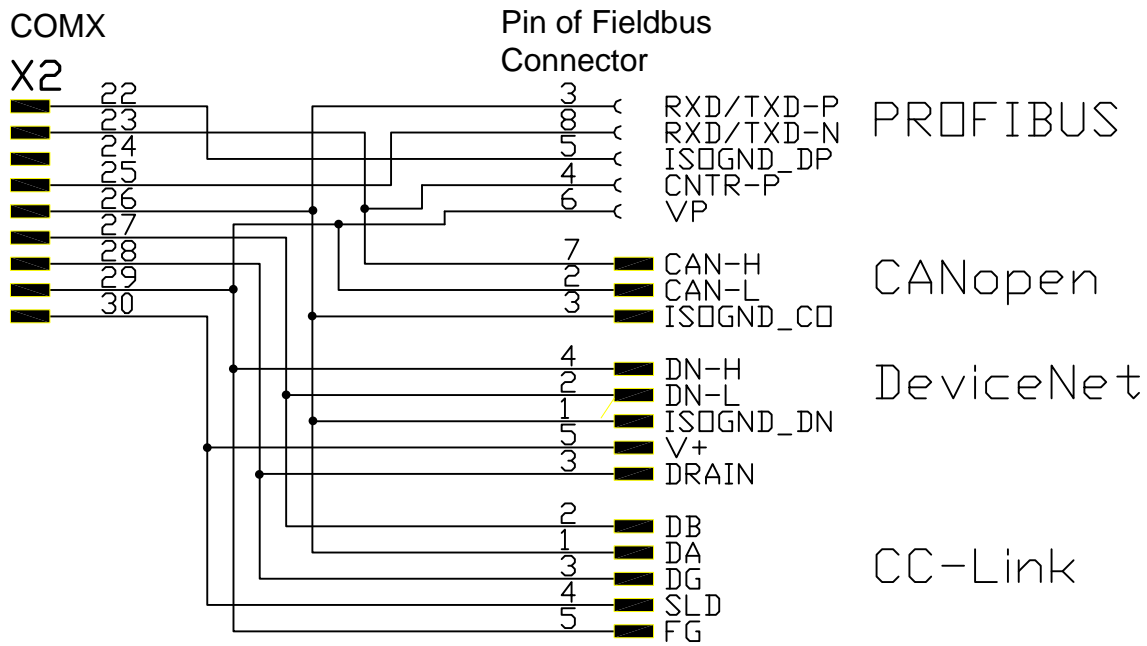

Figure 25: Fieldbus interface connections

3.3 LEDs

To get a fast overview about the status of the module and the communication, two duo-color LEDs are placed on the module respectively can be connected.

SYS defines the general status of the communication module, means starting 2nd stage bootloader, or firmware. On the module we are using the colors yellow for boot and green for firmware loaded.

2nd Status LED shows communication errors or status and communication activities. If there is no definition in the fieldbus standard we use red for error and green for status. If there is a definition we use these for the functions and colors of that LED. For the modules described in that revision of the manual it is only for DeviceNet the case.

The outputs can drive max. 4 mA. If this is too less, an external driver should be placed before the LEDs.

The following schematic shows how to connect the LEDs.

In some cases the brightness of the LEDs of the duo color LEDs are so different that it makes sense to use different resistors to make it equal. This is shown as an example for the LED COM.

The following figure shows the example how to connect the LED for COMX 100CN-CO, COMX 100CN-DN, COMX 100CN-DP. This is the new design for all COMX modules which is compatible to the COM-CN modules.

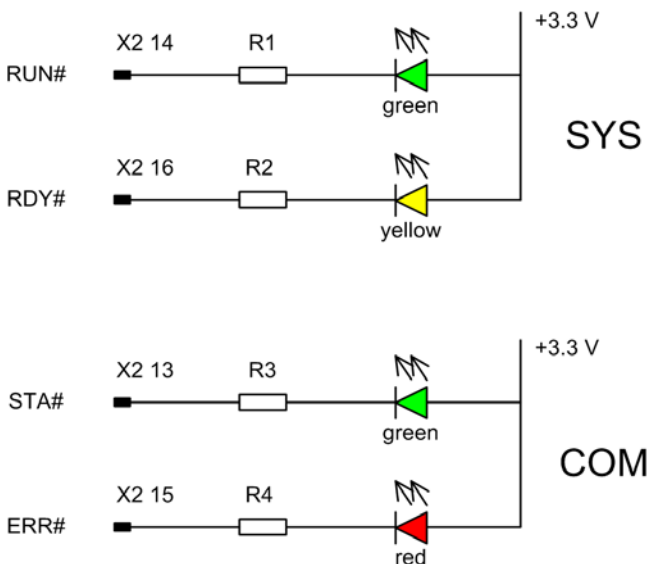

Figure 26: Example how to connect the LEDs COMX CN fieldbus

The following figure shows the example how to connect the LED for COMX CN-RE modules.

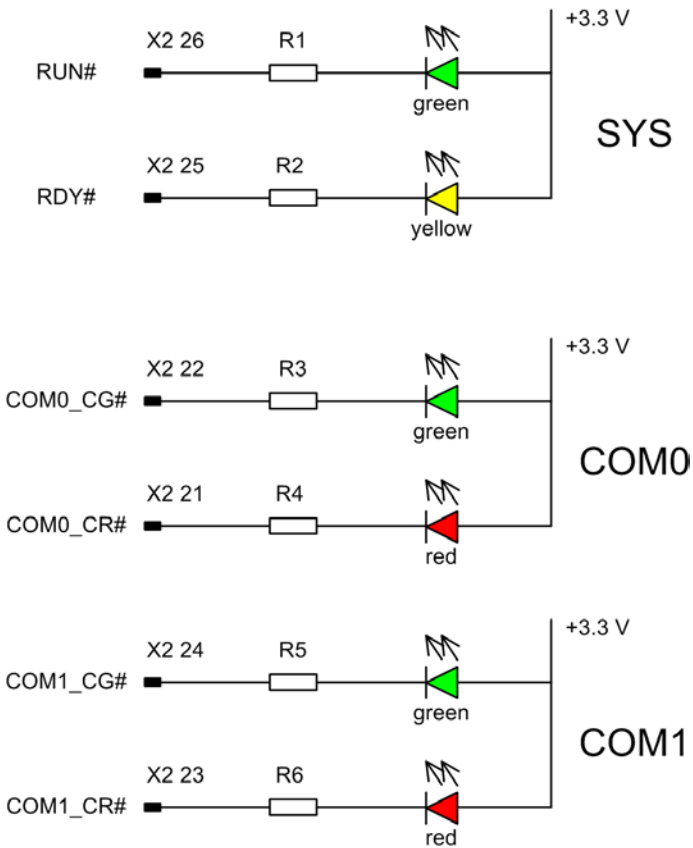

Figure 27: Example how to connect the LEDs COMX CN-RE

The meaning of the LED is documented in [2] (English language) and in [3] (German language).

3.4 Diagnostic interface

3.4.1 Diagnostic interface RS232C

The signals UART0_TXD and UART0_RXD are transmit and receive signals to use with an RS232C interface for diagnostic purpose.

Over this diagnostic line you can download a new firmware, configuration files or make only diagnostic during running communication.

The following schematic shows an example for the RS232C interface necessary on the host board. The module does not have integrated drivers.

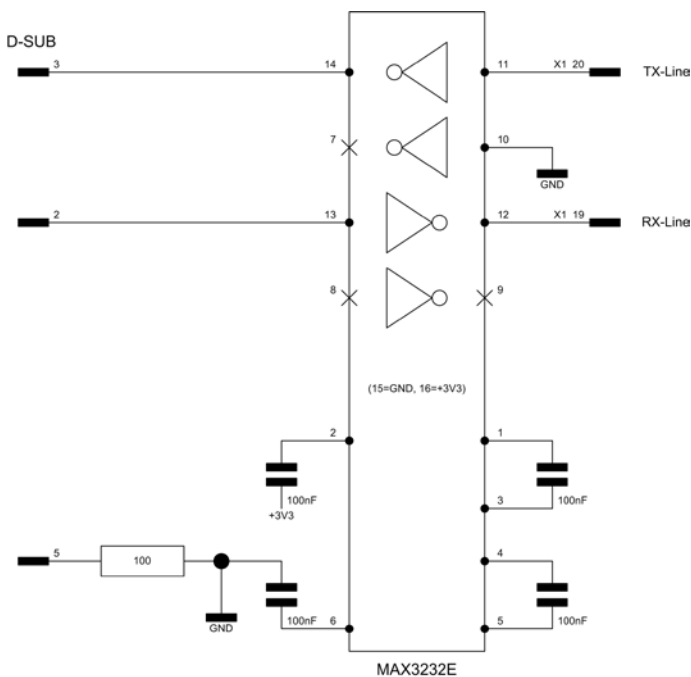

Figure 28: RS232C interface circuit for the diagnostic interface

The diagnostic interface is galvanically coupled (not potential-free).

3.4.2 Diagnostic interface USB

The COMX modules have an USB port for diagnostic.

The following figure shows the circuit for the USB interface.

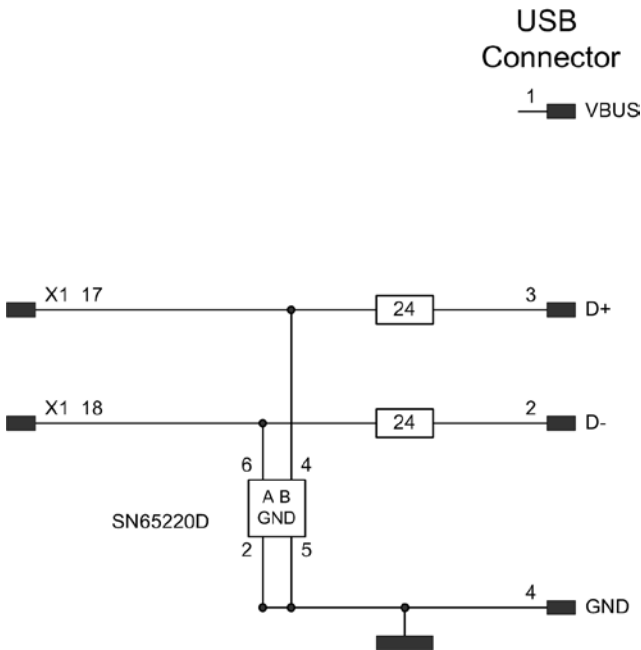

Figure 29: USB interface circuit for the diagnostic interface

This USB interface is for the COMX modules from the following hardware revision:

Module	Hardware revision	Remark
COMX 51CA-RE	1	-
COMX 51CN-RE	1	-
COMX 52CA-CCS	1	-
COMX 52CA-COS	1	-
COMX 52CA-DNS	1	-
COMX 52CA-DPS	1	-
COMX 52CN-CCS	1	-
COMX 52CN-COS	1	-
COMX 52CN-DNS	1	-
COMX 52CN-DPS	1	-
COMX 100CA-CO	4	-
COMX 100CN-CO	3	-
COMX 100CA-DN	4	-
COMX 100CN-DN	3	-
COMX 100CA-DP	4	-
COMX 100CN-DP	3	-
COMX 100CA-RE	7	-
COMX 100CN-RE	2	-

Table 40: Hardware revision of COMX modules with new USB interface

In an earlier version of this document the USB interface was documented with three additional components. These three components need to be removed in order to allow detection of disconnection and reconnection of the USB connection and reestablishment the USB connection in case the COMX module was reset by the operating system Windows.

Don't use the three components as shown in the following figure for the COMX modules revisions listed in table *Hardware revision of COMX modules with new USB interface* on page 60.

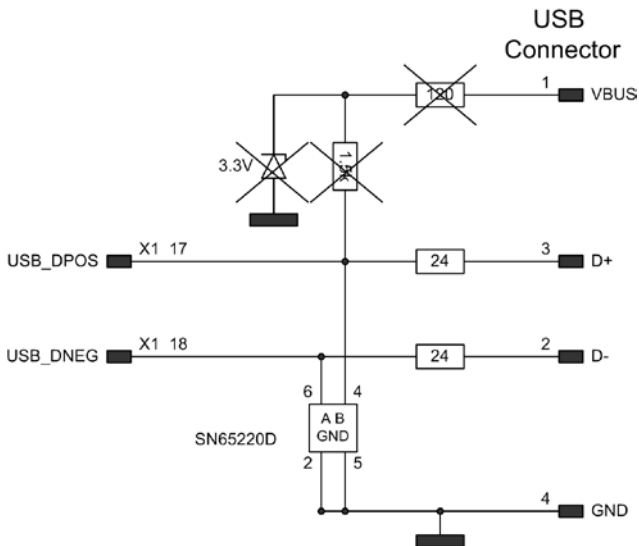
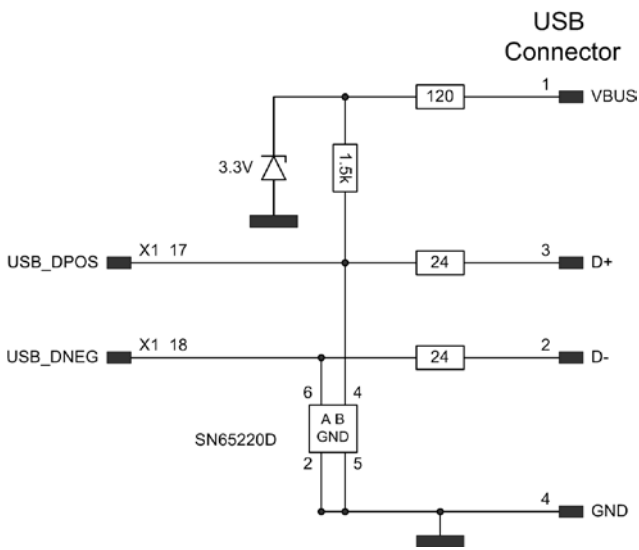

Figure 30: USB interface circuit modification for the diagnostic interface

The schematic for the USB interface for the COMX modules for older revisions is shown in the following figure:



This USB interface is for the COMX modules up to the following hardware revision:

Module	Hardware revision
COMX 100CA-CO	3
COMX 100CN-CO	2
COMX 100CA-DN	3
COMX 100CN-DN	2
COMX 100CA-DP	3
COMX 100CN-DP	2
COMX 100CA-RE	6
COMX 100CN-RE	1

Table 41: Hardware revision of COMX modules with old USB interface

3.5 SYNC signals

COMX modules for Real-Time Ethernet provide SYNC signals. The SYNC Signal has LVTTTL level (3.3 V). A maximum load of 6 mA may not be exceeded. The SYNC signals can only be used if this is supported by the respective firmware, see table below.



NOTICE

Possible destruction of the device due to high current!

Make sure that never two outputs drive against each other. Two outputs that drive against each other cause a too high current and result in device damage. This situation can happen for example, if the host system has an output signal connected to SYNC0 and a firmware is loaded that uses SYNC0 as output, too.

It is also strongly recommended to keep the cable length for the SYNC signals below 50 mm and to take EMC aspects into account.

In general, both SYNC signal lines can be used as input or output. The loaded firmware determines if the signal is an input signal or output signal. The following table shows the meaning of the SYNC signals for the real-time Ethernet protocols currently offering SYNC signal support.

Protocol	Signal IO_SYNC0 Input/Output	Signal IO_SYNC1 Input/Output	From Firm- ware Version	Remarks
EtherCAT Slave	SYNC 0 Output	SYNC 1 Output	-	Configurable
PROFINET IO Device	Bus cycle start (PROFINET IRT) Output	-	3.4.x.x	-
sercos III Master	External trigger to start bus cycle Input Rising edge	-	2.0.8.0	-
sercos III Slave	CON_CLK Output	DIV_CLK Output	3.0.10.0	Configurable

Table 42: Meaning of the SYNC Signals for each Protocol

Note: A PROFINET IO certification for PROFINET IRT requires (mandatory) that the device offers the synchronization signal (SYNC0), in order to allow connecting an oscilloscope. The host system (your product) must provide the SYNC0 signal!

For this purpose, connect the SYNC0 signal and ground of the system connector of the comX with a well accessible 2-pin connector.

4 Technical data

Operating condition			Minimum	Maximum
Operating temperature [° C] air flow 0.5 m/s	COMX 51CA-RE		0 °C	+65 °C
	COMX 51CA-RE\R		-25 °C	+70 °C
	COMX 51CN-RE		-20 °C	+70 °C
	COMX 52CA-CCS		0 °C	+55 °C
	COMX 52CA-COS		-20 °C	+70 °C
	COMX 52CA-DPS		-20 °C	+70 °C
	COMX 52CA-DNS		-20 °C	+70 °C
	COMX 52CN-CCS		0 °C	+55 °C
	COMX 52CN-COS		-20 °C	+70 °C
	COMX 52CN-DPS		-20 °C	+70 °C
	COMX 52CN-DNS		-20 °C	+70 °C
	COMX 100CA-CO		-20 °C	+65 °C
	COMX 100CN-CO		-20 °C	+65 °C
	COMX 100CA-DN		-20 °C	+65 °C
	COMX 100CN-DN		-20 °C	+65 °C
	COMX 100CA-DP		-20 °C	+65 °C
	COMX 100CN-DP		-20 °C	+65 °C
	COMX 100CA-RE		0 °C	+65 °C (Revision 8) +60 °C (Revision 1-7)
	COMX 100CN-RE		-20 °C	+70 °C
	Storage temperature [°C]			-10 °C
Operating voltage [V]		U1	+3.3 V DC – 5 %	+3.3 V DC + 5 %
			Typical	Maximum
Operating current [mA], at +3.3 V DC	COMX 51XX-RE	U1	550 mA	580 mA
	COMX 51CA-RE\R	U1	470 mA	500 mA
	COMX 52CA-CCS	U1	400 mA	410 mA
	COMX 52CA-COS	U1	370 mA	400 mA
	COMX 52CA-DPS	U1	400 mA	440 mA *
	COMX 52CA-DNS	U1	400 mA	440 mA
	COMX 52CN-CCS	U1	400 mA	410 mA
	COMX 52CN-COS	U1	380 mA	400 mA
	COMX 52CN-DPS	U1	400 mA	440 mA
	COMX 52CN-DNS	U1	410 mA	430 mA
	COMX 100XX-CO	U1	450 mA	480 mA
	COMX 100XX-DN	U1	440 mA	470 mA
	COMX 100XX-DP	U1	430 mA	460 mA *
	COMX 100XX-RE	U1	700 mA	700 mA

Table 43: Technical data – Operating conditions

* Maximum current for normal operation

EMC		Generic standard	Basic standard
Immunity		EN 61000-6-2 (1999) Industrial Environment	DIN EN 61000-4-2:2009-12 EN 61000-4-3 DIN EN 61000-4-4:2013-04 DIN EN 61000-4-5:2019-03 EN 61000-4-6 Details are listed in chapter 4.1
Emission		EN 61000-6-4	EN55011

Table 44: Technical data - EMC

Mechanical dimensions	Minimum	Maximum
Dimensions		
COMX	30 x 70 x 21.5 mm	40 x 70 x 21.5 mm for further extension
Weight	35 g	40 g

Table 45: Technical Data – Mechanical dimensions

4.1 Product tests

The following results have been determined in various product tests of the individual versions of COMX.

4.1.1 COMX 51CA-RE

Immunity COMX 51CA-RE				
Generic Standard	Basic Standard	Test	Test level	Error Class
EN IEC 61000-6-2 (2019) Industrial Environment	DIN EN 61000-4-2:2009-12	Electrostatic Discharge		
		Air discharge	± 8 kV	A
		Contact discharge	± 6 kV	B
EN 61131-2 (2008-04)+A11, A12 Programmable Controllers	DIN EN 61000-4-4:2013-04	Burst		
		Communication lines (shielded)	± 2.2 kV fr = 5 kHz	B
	DIN EN 61000-4-5:2019-03	Surge		
		Communication lines (shielded)	1 kV	A

Table 46: Product tests COMX 51CA-RE – Immunity

4.1.2 COMX 51CA-REIR

Immunity COMX 51CA-RE				
Generic Standard	Basic Standard	Test	Test level	Error Class
EN IEC 61000-6-2 (2019) Industrial Environment	DIN EN 61000-4-2:2009-12	Electrostatic Discharge		
		Contact discharge	± 6 kV	A
EN 61131-2 (2008-04)+A11, A12 Programmable Controllers	DIN EN 61000-4-4:2013-04	Burst		
		Communication lines (shielded)	± 2 kV	A
	DIN EN 61000-4-5:2019-03	Surge		
		Communication lines (shielded)	1 kV	A

Table 47: Product tests COMX 51CA-REIR – Immunity

4.1.3 COMX 51CN-RE

Immunity COMX 51CN-RE				
Generic Standard	Basic Standard	Test	Test level	Error Class
EN IEC 61000-6-2 (2019) Industrial Environment	DIN EN 61000-4-2:2009-12	Electrostatic Discharge		
		Air discharge	± 8 kV	A
		Contact discharge	± 6 kV	A
EN 61131-2 (2008-04)+A11, A12 Programmable Controllers	DIN EN 61000-4-4:2013-04	Burst		
		Communication lines (shielded)	± 2.2 kV fr = 5 kHz	B
	DIN EN 61000-4-5:2019-03	Surge		
		Communication lines (shielded)	1 kV	A

Table 48: Product tests COMX 51CN-RE – Immunity

4.1.4 COMX 52CA-CCS

Immunity COMX 52CA-CCS				
Generic Standard	Basic Standard	Test	Test level	Error Class
EN IEC 61000-6-2 (2019) Industrial Environment	DIN EN 61000-4-2:2009-12	Electrostatic Discharge		
		Contact discharge	± 6 kV	A
EN 61131-2 (2008-04)+A11, A12 Programmable Controllers	DIN EN 61000-4-4:2013-04	Burst		
		Communication lines (shielded)	1 kV	A
	DIN EN 61000-4-5:2019-03	Surge		
		Communication lines (shielded)	1 kV	A

Table 49: Product tests COMX 52CA-CCS – Immunity

4.1.5 COMX 52CA-COS

Immunity COMX 52CA-COS				
Generic Standard	Basic Standard	Test	Test level	Error Class
EN IEC 61000-6-2 (2019) Industrial Environment	DIN EN 61000-4-2:2009-12	Electrostatic Discharge		
		Air discharge	± 8 kV	A
		Contact discharge	± 6 kV	A
EN 61131-2 (2008-04)+A11, A12 Programmable Controllers	DIN EN 61000-4-4:2013-04	Burst		
		Communication lines (shielded)	± 2 kV	A
	DIN EN 61000-4-5:2019-03	Surge		
		Communication lines (shielded)	1 kV	A

Table 50: Product tests COMX 52CA-COS – Immunity

4.1.6 COMX 52CA-DPS

Immunity COMX 52CA-DPS				
Generic Standard	Basic Standard	Test	Test level	Error Class
EN IEC 61000-6-2 (2019) Industrial Environment	DIN EN 61000-4-2:2009-12	Electrostatic Discharge		
		Air discharge	± 8 kV	A
		Contact discharge	± 6 kV	A
EN 61131-2 (2008-04)+A11, A12 Programmable Controllers	DIN EN 61000-4-4:2013-04	Burst		
		Communication lines (shielded)	± 2.2 kV	A
	DIN EN 61000-4-5:2019-03	Surge		
		Communication lines (shielded)	1 kV	A

Table 51: Product tests COMX 52CA-DPS – Immunity

4.1.7 COMX 52CA-DNS

Immunity COMX 52CA-DNS				
Generic Standard	Basic Standard	Test	Test level	Error Class
EN IEC 61000-6-2 (2019) Industrial Environment	DIN EN 61000-4-2:2009-12	Electrostatic Discharge		
		Contact discharge	± 6 kV	A
EN 61131-2 (2008-04)+A11, A12 Programmable Controllers	DIN EN 61000-4-4:2013-04	Burst		
		Communication lines (shielded)	± 2.2 kV	A
	DIN EN 61000-4-5:2019-03	Surge		
		Communication lines (shielded)	1 kV	A

Table 52: Product tests COMX 52CA-DNS – Immunity

4.1.8 COMX 52CN-CCS

Immunity COMX 52CN-CCS				
Generic Standard	Basic Standard	Test	Test level	Error Class
EN IEC 61000-6-2 (2019) Industrial Environment	DIN EN 61000-4-2:2009-12	Electrostatic Discharge		
		Contact discharge	± 6 kV	A
EN 61131-2 (2008-04)+A11, A12 Programmable Controllers	DIN EN 61000-4-4:2013-04	Burst		
		Communication lines (shielded)	± 2 kV	A
	DIN EN 61000-4-5:2019-03	Surge Tbd.		
		Communication lines (shielded)	1 kV	A

Table 53: Product tests COMX 52CN-CCS – Immunity

4.1.9 COMX 52CN-COS

Immunity COMX 52CN-COS				
Generic Standard	Basic Standard	Test	Test level	Error Class
EN IEC 61000-6-2 (2019) Industrial Environment	DIN EN 61000-4-2:2009-12	Electrostatic Discharge		
		Contact discharge	± 6 kV	A
EN 61131-2 (2008-04)+A11, A12 Programmable Controllers	DIN EN 61000-4-4:2013-04	Burst		
		Communication lines (shielded)	± 2 kV	A
	DIN EN 61000-4-5:2019-03	Surge		
		Communication lines (shielded)	1 kV	A

Table 54: Product tests COMX 52CN-COS – Immunity

4.1.10 COMX 52CN-DPS

Immunity COMX 52CN-DPS				
Generic Standard	Basic Standard	Test	Test level	Error Class
EN IEC 61000-6-2 (2019) Industrial Environment	DIN EN 61000-4-2:2009-12	Electrostatic Discharge		
		Contact discharge	± 6 kV	A
EN 61131-2 (2008-04)+A11, A12 Programmable Controllers	DIN EN 61000-4-4:2013-04	Burst		
		Communication lines (shielded)	± 2.kV	A
	DIN EN 61000-4-5:2019-03	Surge		
		Communication lines (shielded)	1 kV	A

Table 55: Product tests COMX 52CN-DPS – Immunity

4.1.11 COMX 52CN-DNS

Immunity COMX 52CN-DNS				
Generic Standard	Basic Standard	Test	Test level	Error Class
EN IEC 61000-6-2 (2019) Industrial Environment	DIN EN 61000-4-2:2009-12	Electrostatic Discharge		
		Air discharge	± 8 kV	B
		Contact discharge	± 6 kV	A
EN 61131-2 (2008-04)+A11, A12 Programmable Controllers	DIN EN 61000-4-4:2013-04	Burst		
		Communication lines (shielded)	± 2 kV	A
	DIN EN 61000-4-5:2019-03	Surge		
		Communication lines (shielded)	1 kV	A

Table 56: Product tests COMX 52CN-DNS – Immunity

4.1.12 COMX 100CA-CO

Immunity COMX 100CA-CO				
Generic Standard	Basic Standard	Test	Test level	Error Class
EN IEC 61000-6-2 (2019) Industrial Environment	DIN EN 61000-4-2:2009-12	Electrostatic Discharge		
		Air discharge	± 10 kV	A
		Contact discharge	± 6 kV	A
EN 61131-2 (2008-04)+A11, A12 Programmable Controllers	DIN EN 61000-4-4:2013-04	Burst		
		Communication lines (shielded)	± 2 kV fr = 5 kHz	A
	DIN EN 61000-4-5:2019-03	Surge		
		Communication lines (shielded)	1 kV 2 Ohm / 18 µF	A

Table 57: Product tests COMX 100CA-CO – Immunity

4.1.13 COMX 100CA-DN

Immunity COMX 100CA-DN				
Generic Standard	Basic Standard	Test	Test level	Error Class
EN IEC 61000-6-2 (2019) Industrial Environment	DIN EN 61000-4-2:2009-12	Electrostatic Discharge		
		Air discharge	± 8 kV	B
		Contact discharge	± 4 kV	B
EN 61131-2 (2008-04)+A11, A12 Programmable Controllers	DIN EN 61000-4-4:2013-04	Burst		
		Communication lines (shielded)	± 2 kV fr = 5 kHz	B
		DeviceNet 24 V power supply (unshielded)	± 2 kV fr = 5 kHz	B
	DIN EN 61000-4-5:2019-03	Surge		
		Communication lines (shielded)	1 kV 2 Ohm / 18 µF	B
		DeviceNet 24 V power supply (unshielded) (24 V---PE, GND---PE)	1 kV	B
		DeviceNet 24 V power supply (unshielded) (24 V---GND)	0,6 kV	B

Table 58: Product tests COMX 100CA-DN – Immunity

4.1.14 COMX 100CA-DP

Immunity COMX 100CA-DP				
Generic Standard	Basic Standard	Test	Test level	Error Class
EN IEC 61000-6-2 (2019) Industrial Environment	DIN EN 61000-4-2:2009-12	Electrostatic Discharge		
		Air discharge	± 10 kV	A
		Contact discharge	± 6 kV	A
EN 61131-2 (2008-04)+A11, A12 Programmable Controllers	DIN EN 61000-4-4:2013-04	Burst		
		Communication lines (shielded)	± 2 kV fr = 5 kHz	A
	DIN EN 61000-4-5:2019-03	Surge		
		Communication lines (shielded)	1 kV 2 Ohm / 18 µF	A

Table 59: Product tests COMX 100CA-DP – Immunity

4.1.15 COMX 100CA-RE

Immunity COMX 100CA-RE Rev.8				
Generic Standard	Basic Standard	Test	Test level	Error Class
EN IEC 61000-6-2 (2019) Industrial Environment	DIN EN 61000-4-2:2009-12	Electrostatic Discharge		
		Contact discharge	± 6 kV	B
EN 61131-2 (2008-04)+A11, A12 Programmable Controllers	DIN EN 61000-4-4:2013-04	Burst		
		Communication lines (shielded)	± 2 kV fr = 5 kHz	B
	DIN EN 61000-4-5:2019-03	Surge		
		Communication lines (shielded)	1 kV	A

Table 60: Product tests COMX 100CA-RE Rev.8 – Immunity

4.1.16 COMX 100CN-CO

Immunity COMX 100CN-CO				
Generic Standard	Basic Standard	Test	Test level	Error Class
EN IEC 61000-6-2 (2019) Industrial Environment	DIN EN 61000-4-2:2009-12	Electrostatic Discharge		
		Air discharge	± 10 kV	B
		Contact discharge	± 6 kV	B
EN 61131-2 (2008-04)+A11, A12 Programmable Controllers	DIN EN 61000-4-4:2013-04	Burst		
		Communication lines	± 2 kV fr = 5 kHz	A
	DIN EN 61000-4-5:2019-03	Surge		
		Communication lines (shielded)	1 kV 2 Ohm / 18 µF	A

Table 61: Product tests COMX 100CN-CO – Immunity

4.1.17 COMX 100CN-DN

Immunity COMX 100CN-DN				
Generic Standard	Basic Standard	Test	Test level	Error Class
EN IEC 61000-6-2 (2019) Industrial Environment	DIN EN 61000-4-2:2009-12	Electrostatic Discharge		
		Air discharge	± 10 kV	B
		Contact discharge	± 6 kV	B
EN 61131-2 (2008-04)+A11, A12 Programmable Controllers	DIN EN 61000-4-4:2013-04	Burst		
		Communication lines (shielded)	± 2 kV fr = 5 kHz	B
		DeviceNet 24 V power supply (unshielded)	± 2 kV fr = 5 kHz	B
	DIN EN 61000-4-5:2019-03	Surge		
		Communication lines (shielded)	1 kV 2 Ohm / 18 µF	B
		DeviceNet 24 V power supply (unshielded) (24 V---PE, GND---PE)	1 kV	B
		DeviceNet 24 V power supply (unshielded) (24 V---GND)	0,6 kV	B

Table 62: Product tests COMX 100CN-DN – Immunity

4.1.18 COMX 100CN-DP

Immunity COMX 100CN-DP				
Generic Standard	Basic Standard	Test	Test level	Error Class
EN IEC 61000-6-2 (2019) Industrial Environment	DIN EN 61000-4-2:2009-12	Electrostatic Discharge		
		Air discharge	± 10 kV	B
		Contact discharge	± 6 kV	B
EN 61131-2 (2008-04)+A11, A12 Programmable Controllers	DIN EN 61000-4-4:2013-04	Burst		
		Communication lines (shielded)	± 2 kV fr = 5 kHz	A
	DIN EN 61000-4-5:2019-03	Surge		
		Communication lines (shielded)	1 kV 2 Ohm / 18 µF	A

Table 63: Product tests COMX 100CN-DP – Immunity

4.1.19 COMX 100CN-RE

Immunity COMX 100CN-RE				
Generic Standard	Basic Standard	Test	Test level	Error Class
EN IEC 61000-6-2 (2019) Industrial Environment	DIN EN 61000-4-2:2009-12	Electrostatic Discharge		
		Air discharge	± 8 kV	A
		Contact discharge	± 4 kV	B
EN 61131-2 (2008-04)+A11, A12 Programmable Controllers	DIN EN 61000-4-4:2013-04	Burst		
		Communication lines (shielded)	± 2 kV fr = 5 kHz	B
	DIN EN 61000-4-5:2019-03	Surge		
		Communication lines (shielded)	1 kV 2 Ohm / 18 µF	A

Table 64: Product tests COMX 100CN-RE – Immunity

5 Appendix

5.1 Legal notes

Copyright

© Hilscher Gesellschaft für Systemautomation mbH

All rights reserved.

The images, photographs and texts in the accompanying materials (in the form of a user's manual, operator's manual, Statement of Work document and all other document types, support texts, documentation, etc.) are protected by German and international copyright and by international trade and protective provisions. Without the prior written consent, you do not have permission to duplicate them either in full or in part using technical or mechanical methods (print, photocopy or any other method), to edit them using electronic systems or to transfer them. You are not permitted to make changes to copyright notices, markings, trademarks or ownership declarations. Illustrations are provided without taking the patent situation into account. Any company names and product designations provided in this document may be brands or trademarks by the corresponding owner and may be protected under trademark, brand or patent law. Any form of further use shall require the express consent from the relevant owner of the rights.

Important notes

Utmost care was/is given in the preparation of the documentation at hand consisting of a user's manual, operating manual and any other document type and accompanying texts. However, errors cannot be ruled out. Therefore, we cannot assume any guarantee or legal responsibility for erroneous information or liability of any kind. You are hereby made aware that descriptions found in the user's manual, the accompanying texts and the documentation neither represent a guarantee nor any indication on proper use as stipulated in the agreement or a promised attribute. It cannot be ruled out that the user's manual, the accompanying texts and the documentation do not completely match the described attributes, standards or any other data for the delivered product. A warranty or guarantee with respect to the correctness or accuracy of the information is not assumed.

We reserve the right to modify our products and the specifications for such as well as the corresponding documentation in the form of a user's manual, operating manual and/or any other document types and accompanying texts at any time and without notice without being required to notify of said modification. Changes shall be taken into account in future manuals and do not represent an obligation of any kind, in particular there shall be no right to have delivered documents revised. The manual delivered with the product shall apply.

Under no circumstances shall Hilscher Gesellschaft für Systemautomation mbH be liable for direct, indirect, ancillary or subsequent damage, or for any loss of income, which may arise after use of the information contained herein.

Liability disclaimer

The hardware and/or software was created and tested by Hilscher Gesellschaft für Systemautomation mbH with utmost care and is made available as is. No warranty can be assumed for the performance or flawlessness of the hardware and/or software under all application conditions and scenarios and the work results achieved by the user when using the hardware and/or software. Liability for any damage that may have occurred as a result of using the hardware and/or software or the corresponding documents shall be limited to an event involving willful intent or a grossly negligent violation of a fundamental contractual obligation. However, the right to assert damages due to a violation of a fundamental contractual obligation shall be limited to contract-typical foreseeable damage.

It is hereby expressly agreed upon in particular that any use or utilization of the hardware and/or software in connection with

- Flight control systems in aviation and aerospace;
- Nuclear fission processes in nuclear power plants;
- Medical devices used for life support and
- Vehicle control systems used in passenger transport

shall be excluded. Use of the hardware and/or software in any of the following areas is strictly prohibited:

- For military purposes or in weaponry;
- For designing, engineering, maintaining or operating nuclear systems;
- In flight safety systems, aviation and flight telecommunications systems;
- In life-support systems;
- In systems in which any malfunction in the hardware and/or software may result in physical injuries or fatalities.

You are hereby made aware that the hardware and/or software was not created for use in hazardous environments, which require fail-safe control mechanisms. Use of the hardware and/or software in this kind of environment shall be at your own risk; any liability for damage or loss due to impermissible use shall be excluded.

Warranty

Hilscher Gesellschaft für Systemautomation mbH hereby guarantees that the software shall run without errors in accordance with the requirements listed in the specifications and that there were no defects on the date of acceptance. The warranty period shall be 12 months commencing as of the date of acceptance or purchase (with express declaration or implied, by customer's conclusive behavior, e.g. putting into operation permanently).

The warranty obligation for equipment (hardware) we produce is 36 months, calculated as of the date of delivery ex works. The aforementioned provisions shall not apply if longer warranty periods are mandatory by law pursuant to Section 438 (1.2) BGB, Section 479 (1) BGB and Section 634a (1) BGB [Bürgerliches Gesetzbuch; German Civil Code] If, despite of all due care taken, the delivered product should have a defect, which already existed at the time of the transfer of risk, it shall be at our discretion to either repair the product or to deliver a replacement product, subject to timely notification of defect.

The warranty obligation shall not apply if the notification of defect is not asserted promptly, if the purchaser or third party has tampered with the products, if the defect is the result of natural wear, was caused by unfavorable operating conditions or is due to violations against our operating regulations or against rules of good electrical engineering practice, or if our request to return the defective object is not promptly complied with.

Costs of support, maintenance, customization and product care

Please be advised that any subsequent improvement shall only be free of charge if a defect is found. Any form of technical support, maintenance and customization is not a warranty service, but instead shall be charged extra.

Additional guarantees

Although the hardware and software was developed and tested in-depth with greatest care, Hilscher Gesellschaft für Systemautomation mbH shall not assume any guarantee for the suitability thereof for any purpose that was not confirmed in writing. No guarantee can be granted whereby the hardware and software satisfies your requirements, or the use of the hardware and/or software is uninterrupted or the hardware and/or software is fault-free.

It cannot be guaranteed that patents and/or ownership privileges have not been infringed upon or violated or that the products are free from third-party influence. No additional guarantees or promises shall be made as to whether the product is market current, free from deficiency in title, or can be integrated or is usable for specific purposes, unless such guarantees or promises are required under existing law and cannot be restricted.

Confidentiality

The customer hereby expressly acknowledges that this document contains trade secrets, information protected by copyright and other patent and ownership privileges as well as any related rights of Hilscher Gesellschaft für Systemautomation mbH. The customer agrees to treat as confidential all of the information made available to customer by Hilscher Gesellschaft für Systemautomation mbH and rights, which were disclosed by Hilscher Gesellschaft für Systemautomation mbH and that were made accessible as well as the terms and conditions of this agreement itself.

The parties hereby agree to one another that the information that each party receives from the other party respectively is and shall remain the intellectual property of said other party, unless provided for otherwise in a contractual agreement.

The customer must not allow any third party to become knowledgeable of this expertise and shall only provide knowledge thereof to authorized users as appropriate and necessary. Companies associated with the customer shall not be deemed third parties. The customer must obligate authorized users to confidentiality. The customer should only use the confidential information in connection with the performances specified in this agreement.

The customer must not use this confidential information to his own advantage or for his own purposes or rather to the advantage or for the purpose of a third party, nor must it be used for commercial purposes and this confidential information must only be used to the extent provided for in this agreement or otherwise to the extent as expressly authorized by the disclosing party in written form. The customer has the right, subject to the obligation to confidentiality, to disclose the terms and conditions of this agreement directly to his legal and financial consultants as would be required for the customer's normal business operation.

Export provisions

The delivered product (including technical data) is subject to the legal export and/or import laws as well as any associated regulations of various countries, especially such laws applicable in Germany and in the United States. The products / hardware / software must not be exported into such countries for which export is prohibited under US American export control laws and its supplementary provisions. You hereby agree to strictly follow the regulations and to yourself be responsible for observing them. You are hereby made aware that you may be required to obtain governmental approval to export, reexport or import the product.

5.2 Registered trademarks

Windows® 7, Windows® 8 und Windows® 10 are registered trademarks of Microsoft Corporation.

CANopen® is a registered trademark of CAN in AUTOMATION - International Users and Manufacturers Group e.V. (CiA), Nuremberg.

CC-Link® is a registered trademark of Mitsubishi Electric Corporation, Tokyo, Japan

DeviceNet® is a registered trademark of ODVA (Open DeviceNet Vendor Association, Inc.).

PROFIBUS® is a registered trademark of PROFIBUS International, Karlsruhe.

All other mentioned trademarks are property of their respective legal owners.

5.3 List of tables

Table 1: Basic differences between COM and COMX.....	5
Table 2: Comparison of supported protocols for COM and COMX	5
Table 3: List of revisions	6
Table 4: comX modules – Old and new names.....	9
Table 5: References to documents.....	10
Table 6: Available comX modules	11
Table 7: Minimum required space on top of top side of the printed circuit board.....	13
Table 8: Mechanical dimensions (Drawings overview)	14
Table 9: Connector types	22
Table 10: Usage of bolt for COMX modules.....	26
Table 11: Drawings of bolts (Overview)	26
Table 12: Drawings of assembled bolt (Overview)	26
Table 13: Meaning of the address switch of COMX 52CA-DPS and COMX 52CN-DPS	31
Table 14: Meaning of the address switch of COMX 52CA-COS and COMX 52CN-COS.....	32
Table 15: Meaning of the address switch of COMX 52CA-DNS and COMX 52CN-DNS	32
Table 16: Meaning of the address and baud rate switch of COMX 52CA-CCS and COMX 52CN-CCS.....	33
Table 17: Value range for station address depending on number of stations	33
Table 18: Meaning of the address switch of COMX 51CA-RE\R	34
Table 19: Dual-port memory size and supported modes of the comX modules.....	35
Table 20: Possibilities for usage of dual-port memory	35
Table 21: COMX pin assignment of the system bus connector X1- Parallel DPM mode (Part 1).....	37
Table 22: COMX pin assignment of the system bus connector X1 – Parallel DPM mode (Part 2)	38
Table 23: Notes for COMX pin assignment of the System Bus Connector X1.....	38
Table 24: COMX pin assignment of the system bus connector X1- Serial DPM mode COMX 51/COMX 52 (Part 1)	39
Table 25: COMX pin assignment of the system bus connector X1 – Serial DPM Mode COMX 51/COMX 52 (Part 2).....	40
Table 26: Notes for COMX pin assignment of the system bus connector X1	40
Table 27: PAD type explanation	41
Table 28: Fieldbus connector X2 for CC-Link Slave.....	43
Table 29: Notes for fieldbus connector X2 for CC-Link Slave	43
Table 30: Fieldbus connector X2 for CANopen-Master/-Slave	44
Table 31: Notes for fieldbus connector X2 for CANopen-Master/-Slave.....	44
Table 32: Fieldbus connector X2 for DeviceNet-Master/-Slave.....	45
Table 33: Notes for fieldbus connector X2 for DeviceNet-Master/-Slave.....	45
Table 34: Fieldbus connector X2 for PROFIBUS-Master/-Slave.....	46
Table 35: Notes for fieldbus connector X2 for PROFIBUS-Master/-Slave.....	46
Table 36: Fieldbus connector X2 for Real-Time Ethernet.....	47
Table 37: Function table of the 16 bit decode logic	50
Table 38: Symbols for COMX timing diagram for read and write access	53
Table 39: Function table of decode logic	54
Table 40: Hardware revision of COMX modules with new USB interface.....	60
Table 41: Hardware revision of COMX modules with old USB interface	62
Table 42: Meaning of the SYNC Signals for each Protocol	63
Table 43: Technical data – Operating conditions	64
Table 44: Technical data - EMC	65
Table 45: Technical Data – Mechanical dimensions	65
Table 46: Product tests COMX 51CA-RE – Immunity	66
Table 47: Product tests COMX 51CA-RE\R – Immunity	66
Table 48: Product tests COMX 51CN-RE – Immunity	66
Table 49: Product tests COMX 52CA-CCS – Immunity.....	67
Table 50: Product tests COMX 52CA-COS – Immunity.....	67
Table 51: Product tests COMX 52CA-DPS – Immunity	67
Table 52: Product tests COMX 52CA-DNS – Immunity.....	67
Table 53: Product tests COMX 52CN-CCS – Immunity.....	68
Table 54: Product tests COMX 52CN-COS – Immunity	68
Table 55: Product tests COMX 52CN-DPS – Immunity.....	68
Table 56: Product tests COMX 52CN-DNS – Immunity.....	69
Table 57: Product tests COMX 100CA-CO – Immunity	69
Table 58: Product tests COMX 100CA-DN – Immunity	69
Table 59: Product tests COMX 100CA-DP – Immunity	70
Table 60: Product tests COMX 100CA-RE Rev.8 – Immunity	70
Table 61: Product tests COMX 100CN-CO – Immunity.....	70
Table 62: Product tests COMX 100CN-DN – Immunity	71
Table 63: Product tests COMX 100CN-DP – Immunity	71
Table 64: Product tests COMX 100CN-RE – Immunity	71

5.4 List of figures

Figure 1: Block diagram of the COMX modules	8
Figure 2: COMX CA type - Connector X1	12
Figure 3: COMX CN type - Connectors X1 and X2	12
Figure 4: General Mechanical dimension of COMX-CA-XXX	15
Figure 5: Mechanical dimension of COMX-CN-XXX	16
Figure 6: Mechanical dimension of light pipe of COMX 51/52/100CA-XXX.....	17
Figure 7: Mechanical dimension of cover and connector of COMX 51/100CA-RE and COMX 51CA-REIR.....	18
Figure 8: Mechanical dimension of cover and connector of COMX 51CA-REIR	19
Figure 9: Mechanical dimension of cover and connector of COMX 52CA-XXX (Fieldbus)	20
Figure 10: Mechanical dimension of cover and connector of COMX 100CA-XXX (Fieldbus).....	21
Figure 11: TFM connector.....	23
Figure 12: How to layout the signals at the connectors X1 and X2	25
Figure 13: Mechanical dimension of Bolt COM-CA-B20X5.....	27
Figure 14: Mechanical dimension of Bolt COM-CA-B31,5X5.....	28
Figure 15: Mechanical dimension of Bolt COM-CA-B24X5.....	29
Figure 16: Mechanical dimension how to assemble COM-CA-XXX on the motherboard.....	30
Figure 17: Example matrix code label of COMX modules	31
Figure 18: Schematic view of netX pad types	42
Figure 19: Ethernet connection COMX-CN-RE	48
Figure 20: Ethernet connector example (ERNI 203313).....	48
Figure 21: COMX timing diagram for read access.....	52
Figure 22: COMX timing diagram for write access	52
Figure 23: Interface with 8-bit data bus - Interface with 16-bit interface	54
Figure 24: Serial dual-port memory interface	55
Figure 25: Fieldbus interface connections	56
Figure 26: Example how to connect the LEDs COMX CN fieldbus	57
Figure 27: Example how to connect the LEDs COMX CN-RE	58
Figure 28: RS232C interface circuit for the diagnostic interface	59
Figure 29: USB interface circuit for the diagnostic interface	60
Figure 30: USB interface circuit modification for the diagnostic interface.....	61

5.5 Contacts

Headquarters

Germany

Hilscher Gesellschaft für Systemautomation mbH
Rheinstraße 15
D-65795 Hattersheim
Phone: +49 (0) 6190 9907-0
Fax: +49 (0) 6190 9907-50
E-mail: info@hilscher.com

Support

Phone: +49 (0) 6190 9907-990
E-mail: hotline@hilscher.com

Subsidiaries

China

Hilscher Systemautomation (Shanghai) Co. Ltd.
200010 Shanghai
Phone: +86 (0) 21-6355-5161
E-mail: info@hilscher.cn

Support

Phone: +86 (0) 21-6355-5161
E-mail: cn.support@hilscher.com

France

Hilscher France S.a.r.l.
69800 Saint Priest
Phone: +33 (0) 4 72 37 98 40
E-mail: info@hilscher.fr

Support

Phone: +33 (0) 4 72 37 98 40
E-mail: fr.support@hilscher.com

India

Hilscher India Pvt. Ltd.
Pune, Delhi, Mumbai, Bangalore
Phone: +91 8888 750 777
E-mail: info@hilscher.in

Support

Phone: +91 8108884011
E-mail: info@hilscher.in

Italy

Hilscher Italia S.r.l.
20090 Vimodrone (MI)
Phone: +39 02 25007068
E-mail: info@hilscher.it

Support

Phone: +39 02 25007068
E-mail: it.support@hilscher.com

Japan

Hilscher Japan KK
Tokyo, 160-0022
Phone: +81 (0) 3-5362-0521
E-mail: info@hilscher.jp

Support

Phone: +81 (0) 3-5362-0521
E-mail: jp.support@hilscher.com

Republic of Korea

Hilscher Korea Inc.
13494, Seongnam, Gyeonggi
Phone: +82 (0) 31-739-8361
E-mail: info@hilscher.kr

Support

Phone: +82 (0) 31-739-8363
E-mail: kr.support@hilscher.com

Austria

Hilscher Austria GmbH
4020 Linz
Phone: +43 732 931 675-0
E-mail: sales.at@hilscher.com

Support

Phone: +43 732 931 675-0
E-mail: at.support@hilscher.com

Switzerland

Hilscher Swiss GmbH
4500 Solothurn
Phone: +41 (0) 32 623 6633
E-mail: info@hilscher.ch

Support

Phone: +41 (0) 32 623 6633
E-mail: support.swiss@hilscher.com

USA

Hilscher North America, Inc.
Lisle, IL 60532
Phone: +1 630-505-5301
E-mail: info@hilscher.us

Support

Phone: +1 630-505-5301
E-mail: us.support@hilscher.com